

# D-200

## MURPHY DESK BED KIT

QUEEN SIZE

**WARNING!**

**DO NOT DEVIATE FROM THESE PLANS.**

WARNING! ALL MURPHY/WALL BED SYSTEMS CONTAIN STORED ENERGY. FAILURE TO USE AND FOLLOW THESE INSTRUCTIONS DURING THE INSTALLATION PROCESS COULD RESULT IN SEVERE PERSONAL INJURY TO THE USER OR DAMAGE TO PRODUCT. PLEASE CONTACT CUSTOMER SERVICE AT 866-725-6401 FOR ANY QUESTIONS.



# Recommendations to Start the Project

---

## Cabinet Material:

IT IS STRONGLY RECOMMENDED TO CONSTRUCT MURPHY BED CABINET USING 4 X 8 PLY CORE (FURNITURE GRADE) PANELS. MDF MAY BE USED BUT THE BED MAY BE HEAVY TO OPERATE. PARTICLE BOARD CANNOT BE USED FOR THIS PROJECT. See Cut Lists on following pages.

## Project Steps:

1. Cut, Mill and Edge band all bed cabinetry parts as detailed in these instructions.
2. Apply finish as desired to all cabinet parts as indicated in these instructions.
3. Final Assemble the Murphy bed in the room it is to be used.
4. Anchor cabinetry (bed cabinet) to structural members (i.e. wood studs) in your wall.
5. Familiarize yourself with all of the mechanism components.
6. Install lift mechanism to the bed cabinetry parts as illustrated in these instructions

## Recommended Wood Working Tools for this project:

- Table Saw or Skill saw with a guide for cutting Plywood Panels and Solid wood pieces.
- Jig Saw
- A complete set of Drill bits, and a Countersink bit.
- Assorted Forstner type Drill Bits including 3/4", 13/16" and 1 1/8"
- Assorted wood working Clamps up to 36"
- Iron for edge banding (household Iron is fine)
- Power Drill and Power Screw driver with Phillips and Square bits
- Chop saw or Hand miter saw.
- 18 gage brad nail finish gun with 1 1/4" nails are recommended for positioning Project Steps:
- Power sander (orbital) 150 or 180 grit as desired
- Router with a 13/16" straight or spiral router bits for cutting dados.
- Finishing supplies

## Mechanism Box Contents

Quantity	Item
2	Lifting Arm -- 1 left and 1 right
2	Lower Bracket
2	Clevis Pin
2	Cotter Pin
6	Threaded Steel Barrel
2	50mm Bolt
2	Pivot Post
2	Black Flange
4	3/4" Pan-head Screw
4	Thin Triangle Plate -- 2 left and 2 right
2	Heavy Triangle Plate w/ Post
2	Plunge Lock
12	6.5mm Machine Screw
2	Ball Stud -- These may come, already installed in the lifting arm.
2	Piston
4	40mm Furniture Screw
4	1/4" Barrel Nut
8	5/8" Machine Screw
8	3/16" Barrel Nut
3	#8 x 3 1/2" Washer Headed Wood Screw
8	#12 X 3/4" Wood Screw (8)
8	Black Decorative Washers

### Items to Source Locally:

Quantity	Item
150	#8 x 1 1/4" Wood Screw
30	#8 x 2" Wood Screw
15	#8 x 2 1/2" Wood Screw
6	4' x 8' Furniture Grade Plywood Panels; MDF may be used but not recommended due to weight and strength. Particle Board can not be used in the construction of this project.
120'	13/16" Pre-glued Iron on Edge Tape sourced to match wood species
Solid wood	Solid Wood Boards as per cut list see page 3 "Solid Wood Cut List"
Bottle	Wood Glue
As Desired	Stain, Lacquer, or Polyurethane
Assorted	Sandpaper as desired
As Desired	Handles and Knobs
2	1" Elastic Strap (20" Long) See Page 34

## Queen Size Bed Cut Lists

For best results, it is strongly recommended to construct Murphy bed cabinet using 4' x 8' ply core (furniture grade) panels. MDF may be used. Particle board cannot be used for this project.

<u>Queen Size Bed</u>			<u>Overall Cabinet Dimensions</u>	
Mattress Size: 60" x 80" 12" Max Thickness		Ply Wood Cut List		75 5/8"H x 86 1/4"W x 46"D
Quantity	Description	Width	Length	Edge Banding
2	Bed Face Panels	39 15/16"	60 3/8"	No Edge Banding
2	Sideboards	20 7/8"	74 1/8"	One Long Edge (Front)
1	Bridge Board	20 7/8"	86 1/4"	Both Short Ends
1	Headboard	15"	84 3/4"	One Long Edge
1	Front Stretcher	7 1/8"	84 3/4"	One Long Edge
2	Bed Stop	12 1/4"	2 1/2"	One long edge & both ends
2	Bed Stop Support	12 1/4"	2"	Both Short Ends
1	Mattress Stiffener	6"	59 15/16"	No Edge Banding
2	Side Rails	20 5/16"	61 5/16"	All Edges
1	Front Rail	87 1/16"	80"	Both Long Edges
1	Back Rail	6"	80"	One Long Edges
1	Desk	25 7/16"	80"	One Long Edges
1	Desk Back	4 1/2"	80"	One Long Edges
2	Desk Ends	5 1/8"	27 5/8"	All Edges

<u>Queen Size Bed</u>			<u>Solid Wood Cut List</u>		
Quantity	Item	Width	Length	Thick	Description
1	Bridge Face	17/8"	86 1/4"	13/16"	Attaches to the front of the Bridge Board
1	Bridge Support Cleat	11/2"	82"	13/16"	Supports the Bridge Front
1	Bridge Front	17/8"	82"	13/16"	Attaches to the Bridge Board's front
1	Anchor Board	11/8"	86 1/4"	13/16"	Attaches to the Bridge Board's Back
2	Sideboard Fill Attachment	13/8"	42"	13/16"	Attaches to the front of the Sideboards
2	Side Rail Cleat	11/8"	60 13/16"	13/16"	Attaches in the dados of the Side Rails
1	Back Rail Cleat	11/8"	78 3/16"	13/16"	Inserts into the dado in the Back Rail
1	Front Rail Cleat	11/8"	78 3/16"	13/16"	Inserts into the dado in the Front Rail
2	Desk Cleat	13/8"	21"	13/16"	Supports the Desk Ends
1	Desk Front	17/8"	80"	13/16"	Attaches in the dado of the Desk
1	Desk Support	11/2"	80"	13/16"	Supports the Desk Front
2	8' Solid Wood Cleats	13/16"	96"	13/16"	Cut to various lengths and used to assemble the Bed and Cabinet Surround
As desired	Optional Bed Face Molding				Used for decorating the Face Panels*

\*Bed Face Molding are trim Pieces that can be added to the Front of the Bed's face to add style to fit a decor choice. Bed Molding cannot be thicker than 3/8" (see pg 12 for more detail).

# Suggested Panel Layout on 4x8 Sheets

Sheet 1

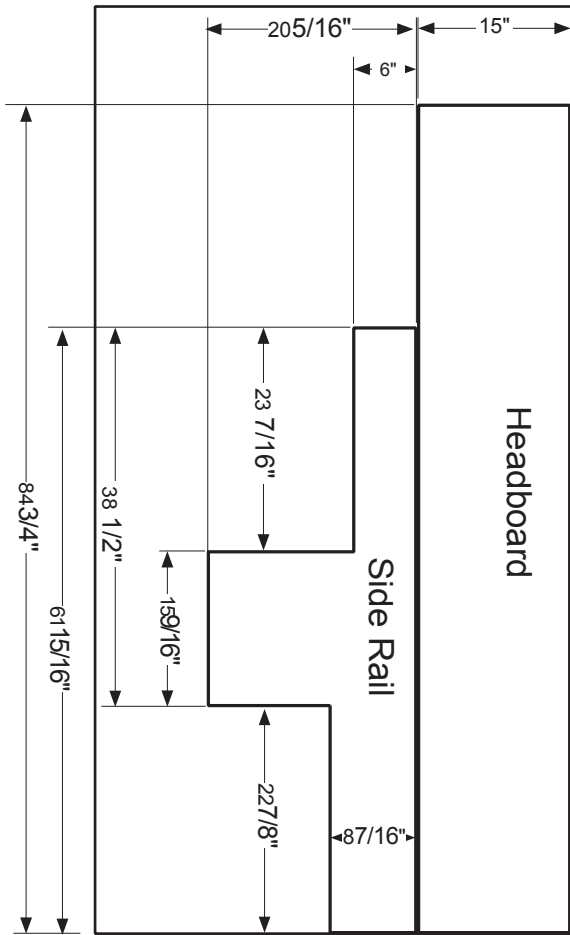

Sheet 2

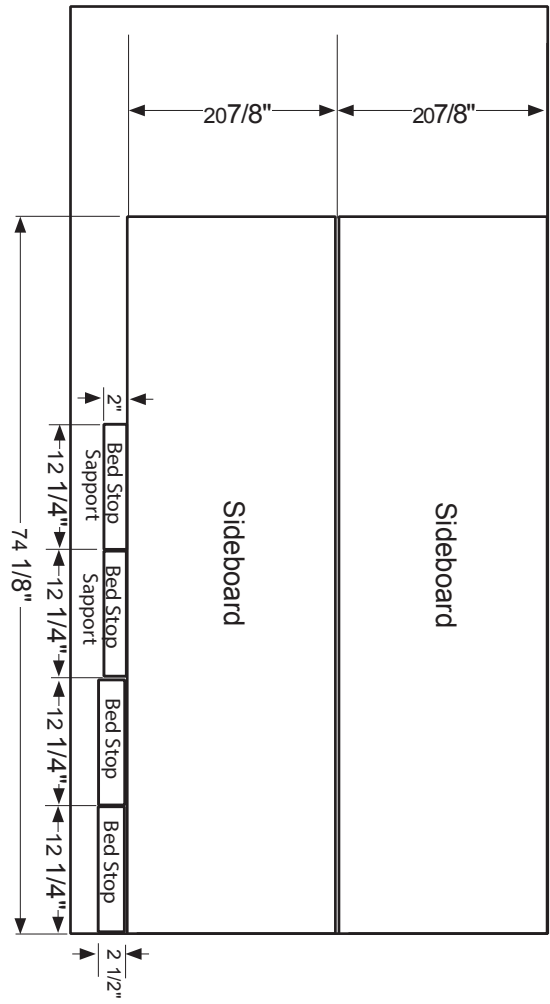

Sheet 3

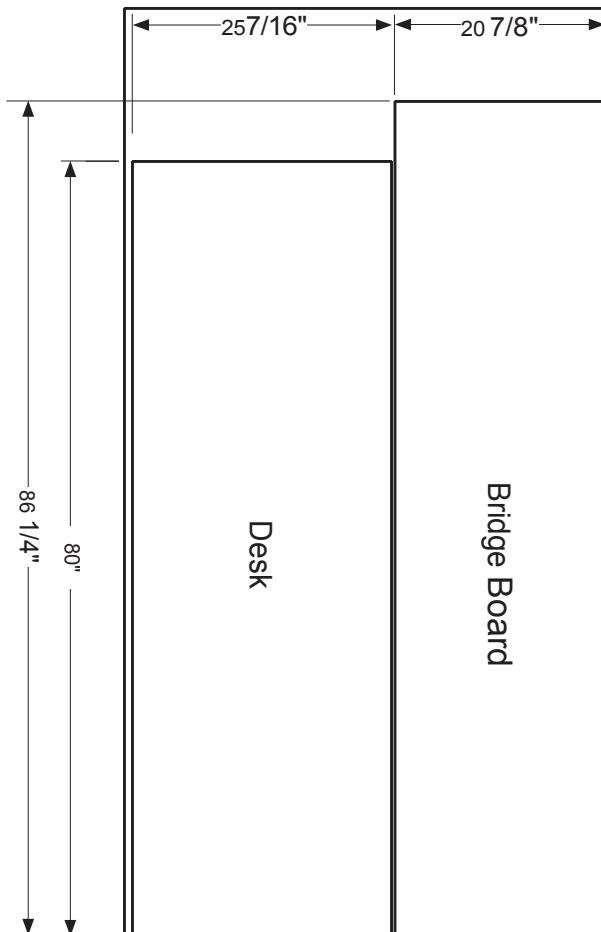

# Suggested Panel Layout on 4x8 Sheets cont.

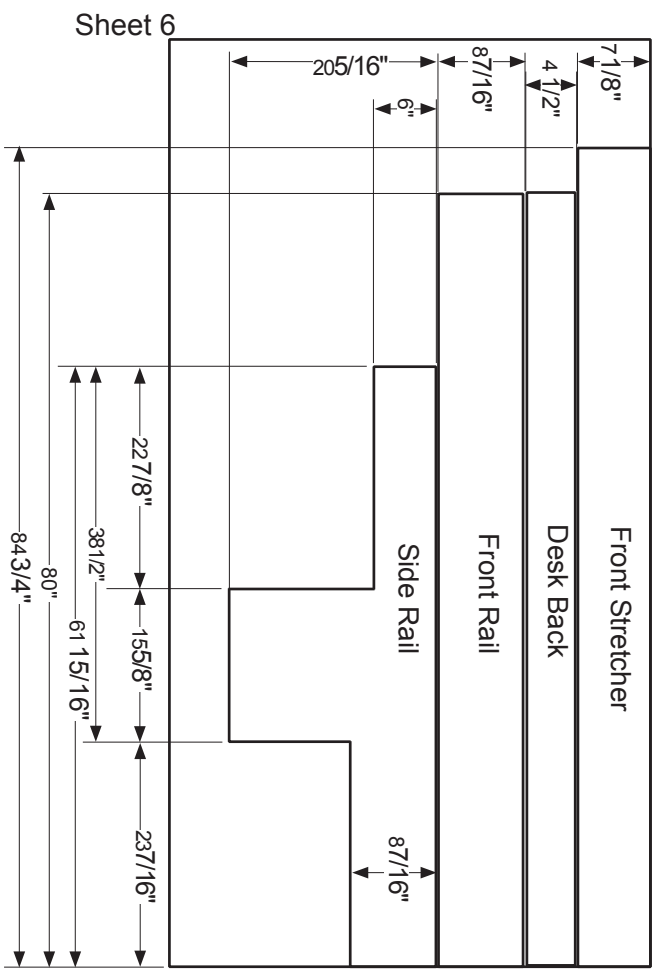
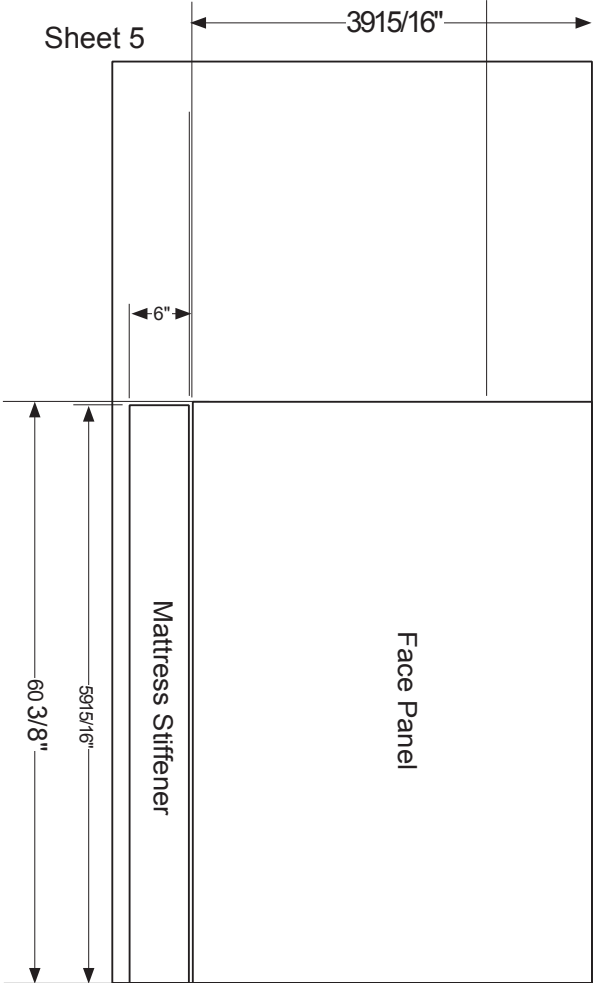
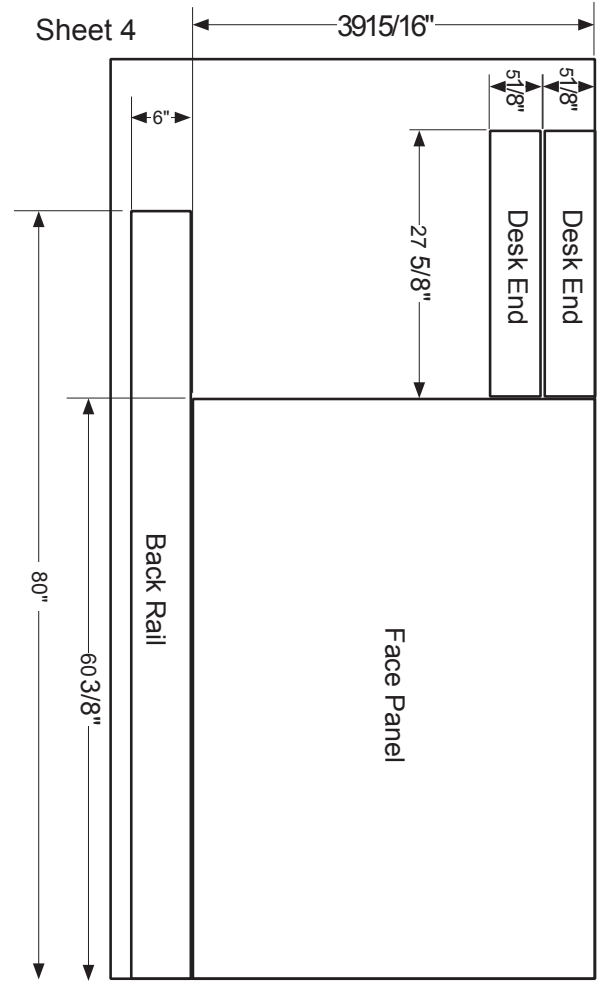

## Step 1: Cutting Radius on Side Rails

Using a Jig Saw carefully cut a 2" radius on the top back of both Side Rails.

Drill two 3/16" holes on each end as illustrated.

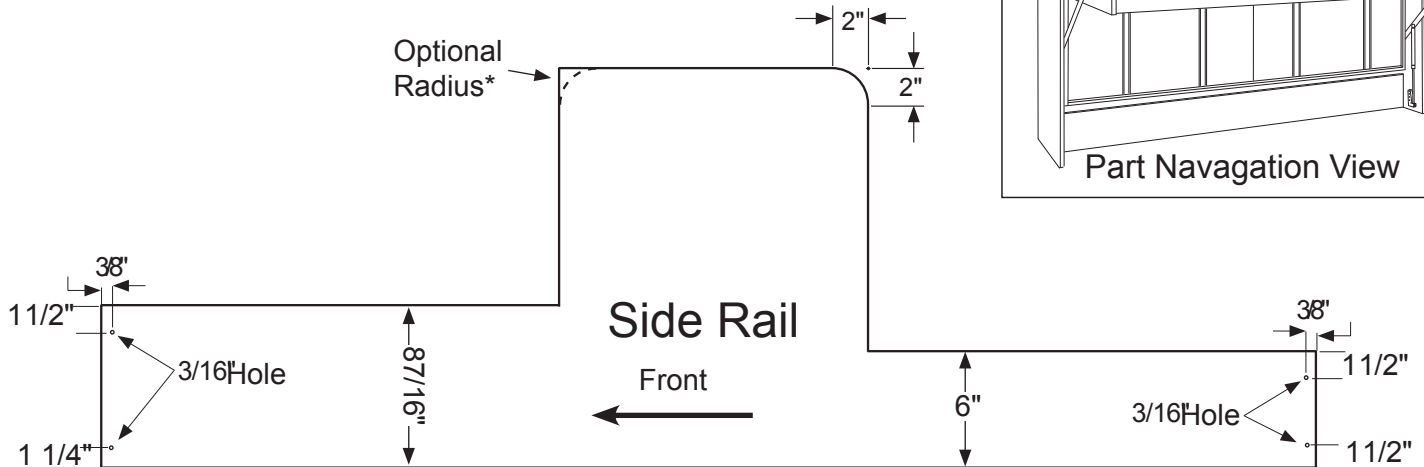

\*Optional Radius: As an option you can cut a 2" radius on the front side of the Side Rail Hump to match the mandatory radius on the back of the Hump. This will soften the corner as illustrated in the part navigation view above right.

## Optional Radius cuts for the Desk Ends

If desired, you can soften the front top corner of the Desk Ends by cutting a small radius on the top corner of these two pieces. They will be edge banded in a later step.

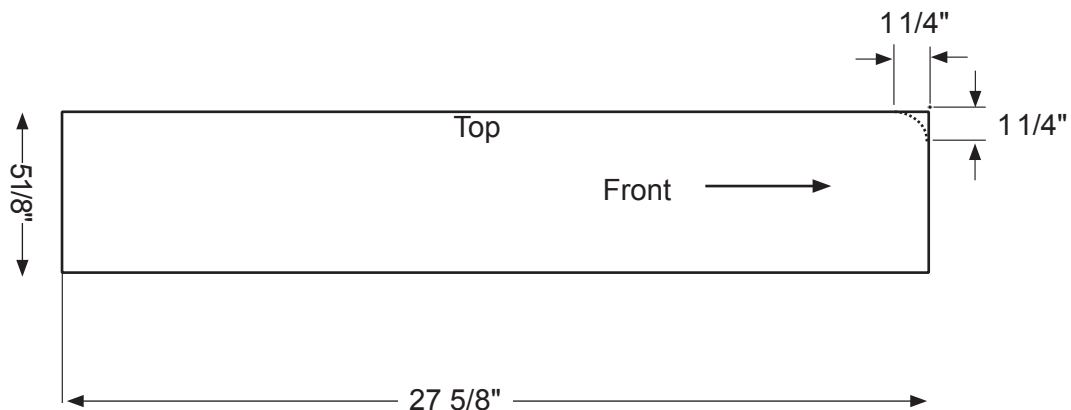
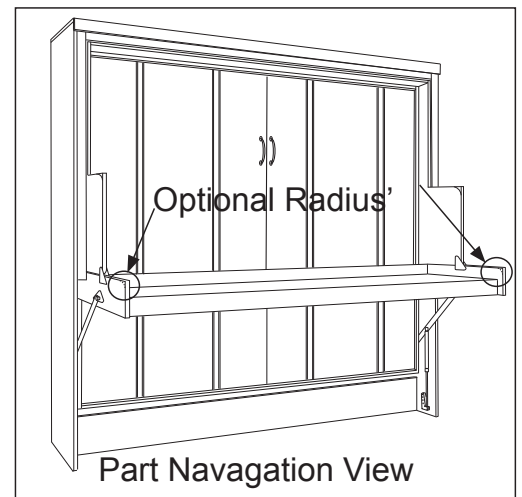



## Step 2: Cutting Dados into all necessary Bed Rails Parts

Use a Router or Dado Blade/Chisel to cut a dados as illustrated

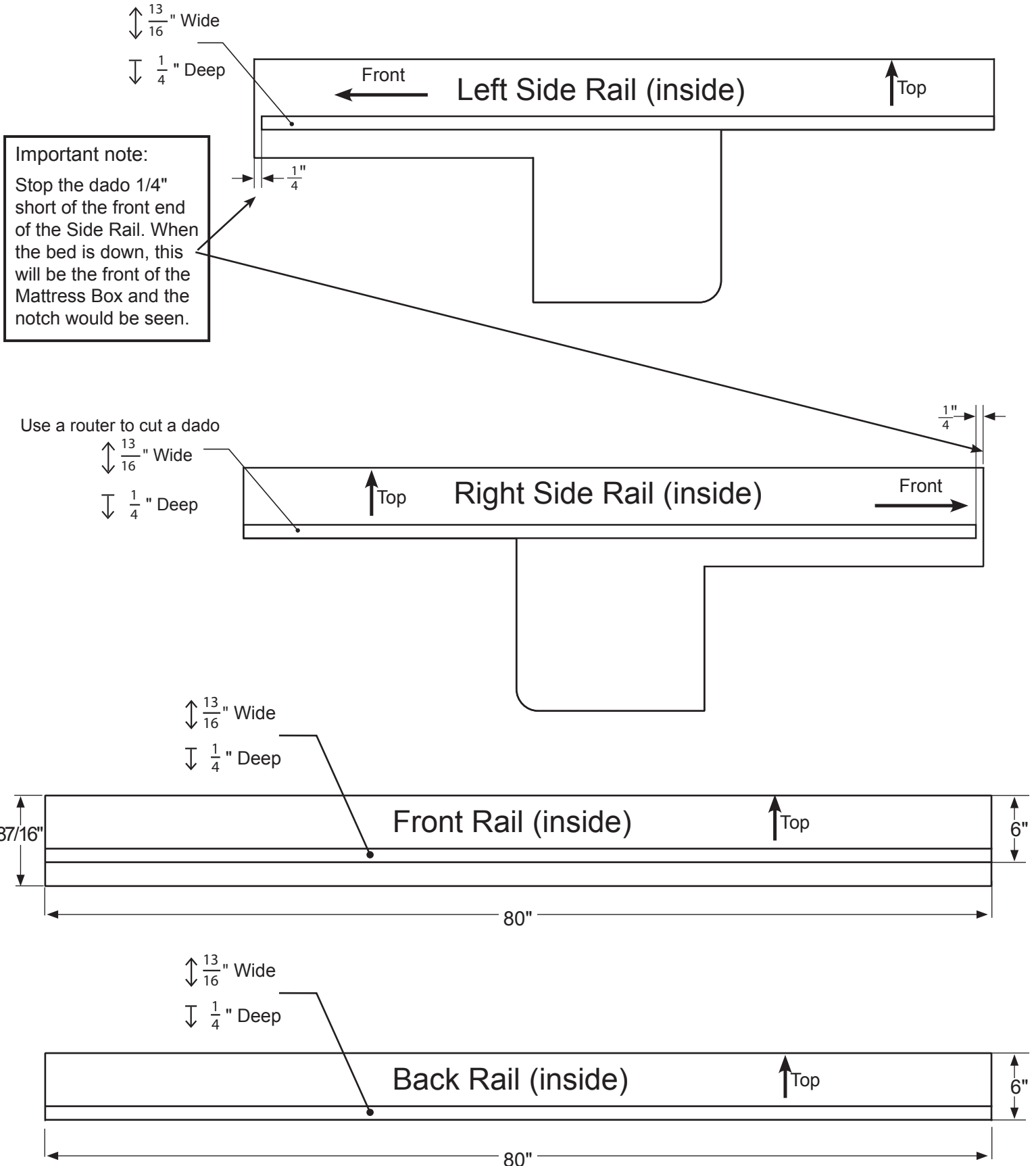

### Step 3: Edge banding Bed and Desk Parts

Apply Edge Banding to ALL Edges of the Left Side Rail.

Apply Edge Banding to ALL Edges of the Right Side Rail.

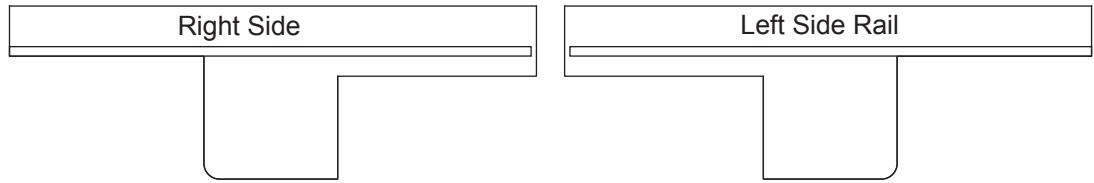

Apply Edge Banding the Bed and Desk Parts as labeled.

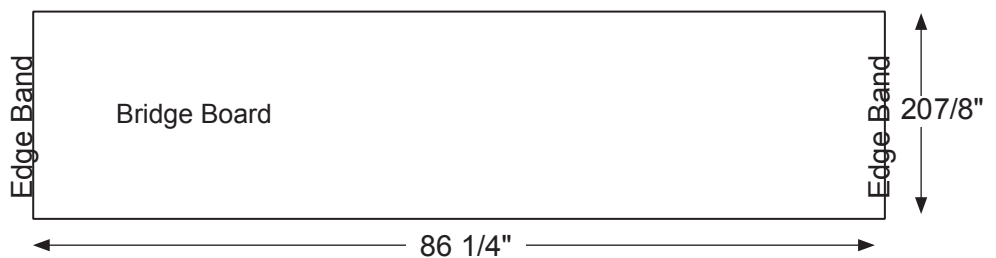
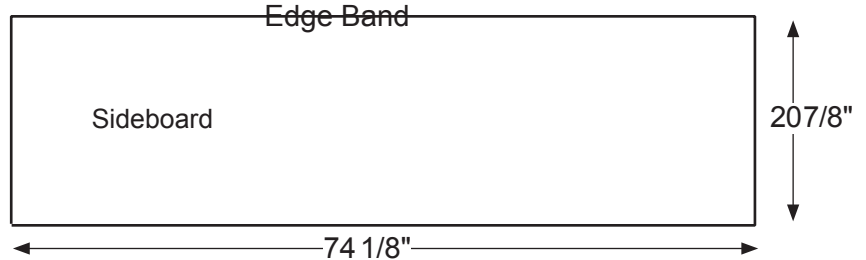
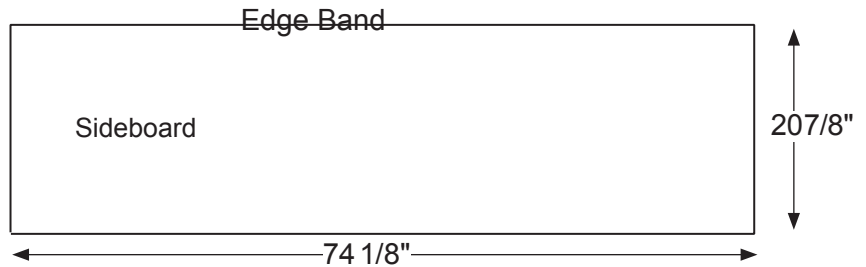
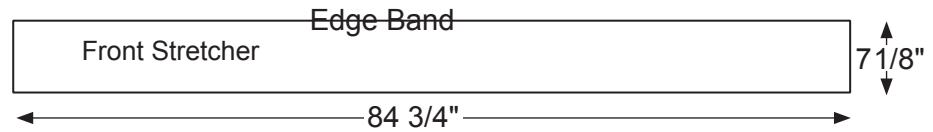
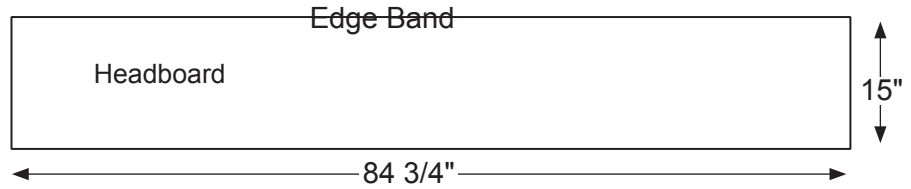
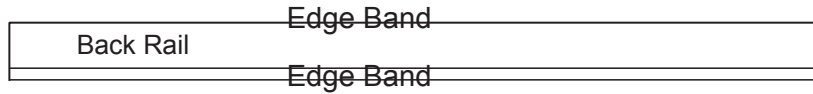
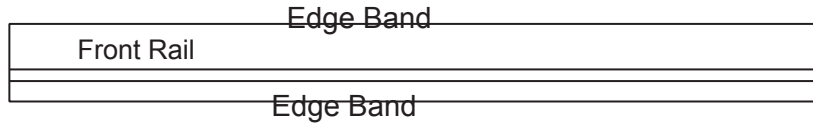

**Step 3: Edge banding Bed and Desk Parts Cont.**

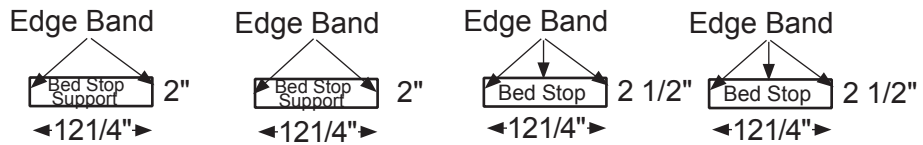
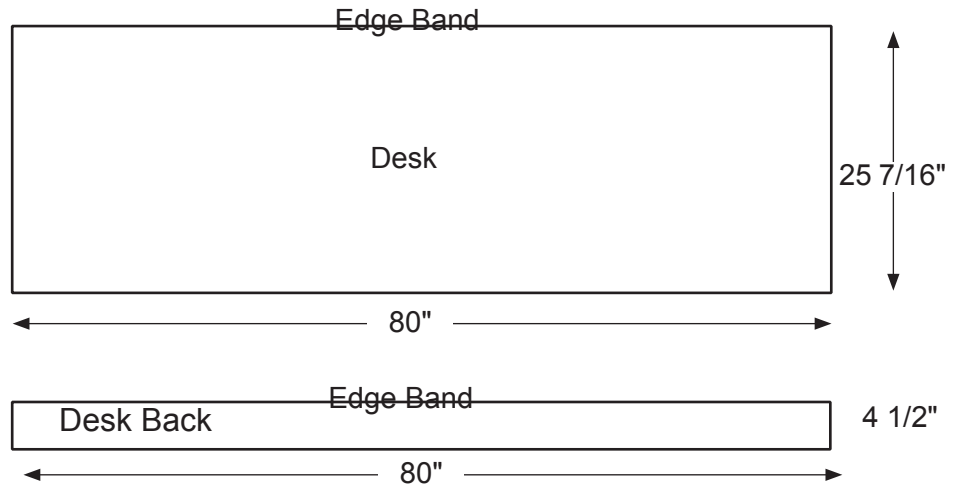

Apply Edge Band to ALL edge of Desk Ends

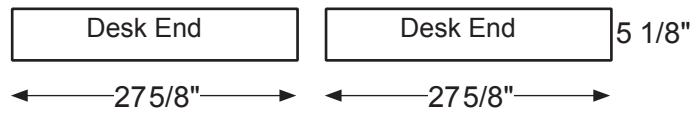

**Step 4: Side Board Preparations.**

This step requires drill bit Sizes 3/8" and Forstner bits 3/4" and 13/16"

Prepare the Side Boards for the Lift Mechanism by drilling holes as outlined in the illustration.

Repeat on the Left Side Board so it mirrors the Right Side Board.

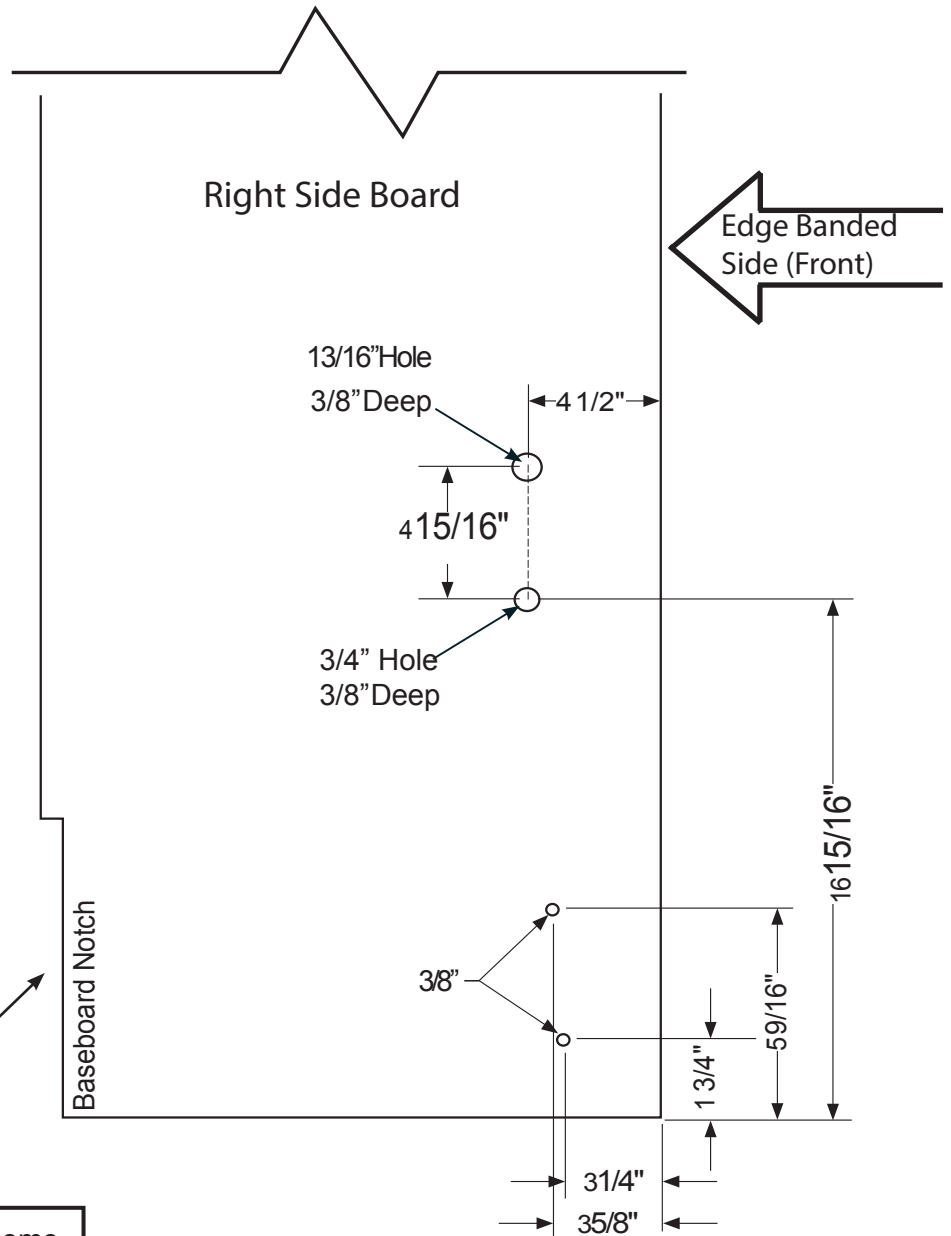

Optional Cut Out for Baseboard in Home

If there is a baseboard on the intended installation wall, there is the option to cut out the back bottom of the Side Board for easy installation (Recommended). The dimensions of this notch should be the dimensions of the baseboard + 1/4".

Maximum cut out not to exceed 1" wide or 9" high. If baseboard exceeds these dimensions baseboard, or baseboard shoe molding will need to be removed during installation process.

## Step 4: Side Board Preparations Cont.

From the mechanism box locate the Right Lifting Arm. Now place the Lifting Arm against the Sideboard by inserting the protrusions on the back of the Lifting Arm into the previously drilled holes. Then Use the Lifting Arm only as a template, drilling through the Side Boards with a 1/4" drill bit ONLY in the upper 2, and lower 2 holes as shown.

Place the Lifting Arm Back in the box to be reinstalled during final assembly.

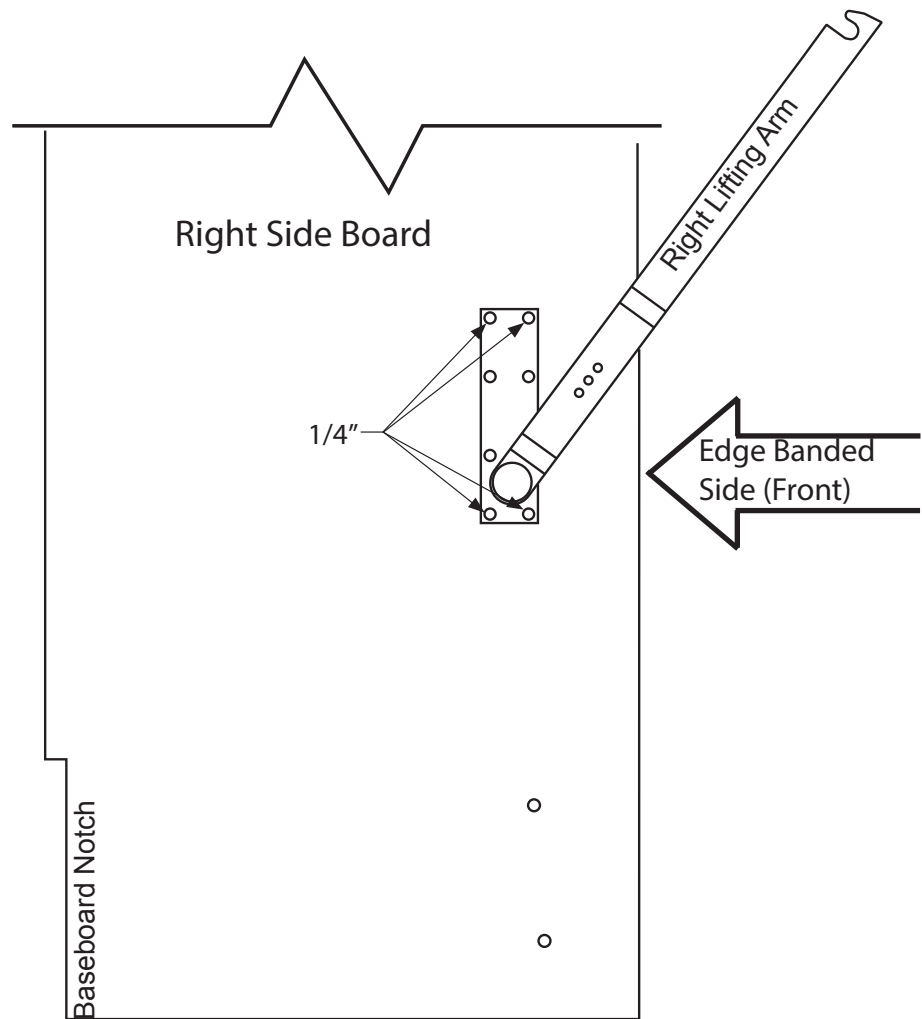

Repeat on Left Side Board

## Step 5: Preparing Side Rails

As illustrated, drill holes through the Side Rail as shown.

Repeat process on Right Side Rail so Side Rails mirror each other.

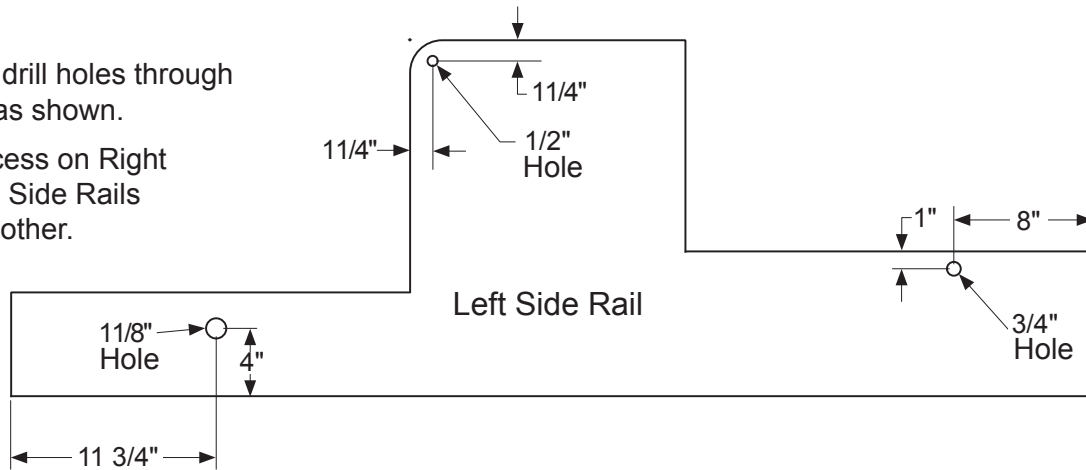

## Step 6: Preparing Face Panels

Face Panels will be the front of the Bed when the Bed is closed. Best grain, overall appearance and match will be important so chose the sides, grain pattern etc that suits you best. Once you have chosen Face lay-out, drill  $3/16$ " holes around the perimeter of the panels. THERE SHOULD NOT BE HOLES WHERE THE PANELS WILL MEET IN THE CENTER OF THE BED FACE.

Important note: The  $3/16$ " holes drilled around the parameter must be  $3/8$ " from the edge so they are not seen when the bed is assembled.

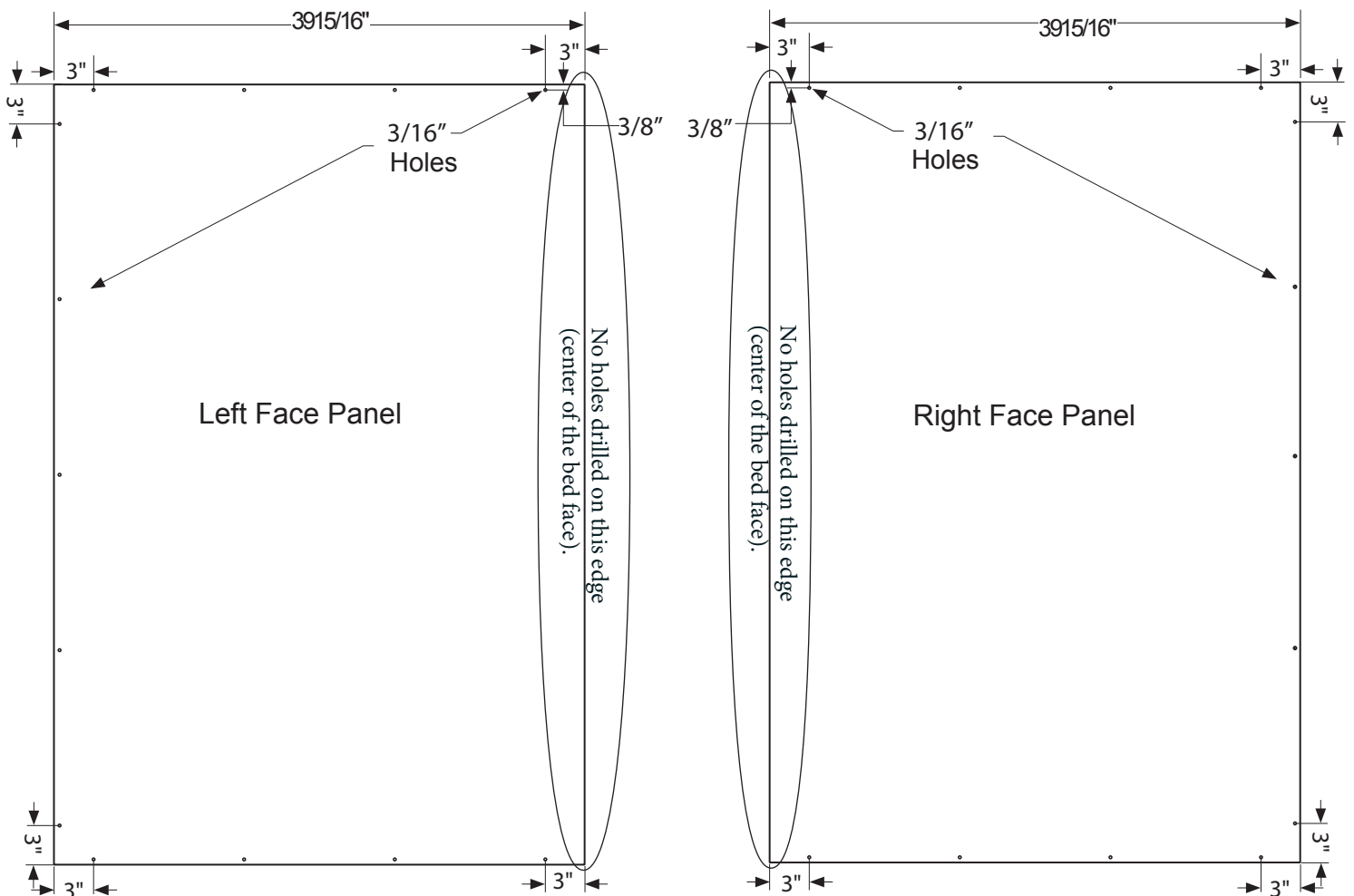

## Optional Step 6: Preparing Face

Panels cont.

If you would like to apply decorative molding to the Face Panels for design purposes, please note that the molding pieces must stop  $7/8$ " from the Face Panel's TOP, BOTTOM, and OUT SIDE EDGES. Applied decorative Molding can be positioned at the edge of the panels where they will meet in the middle. Molding cannot be thicker than  $3/8$ ". Note the desk location shown on the panels below is to help you in laying out your design elements. Molding can pass behind the desk but must not be thicker than  $3/8$ ".

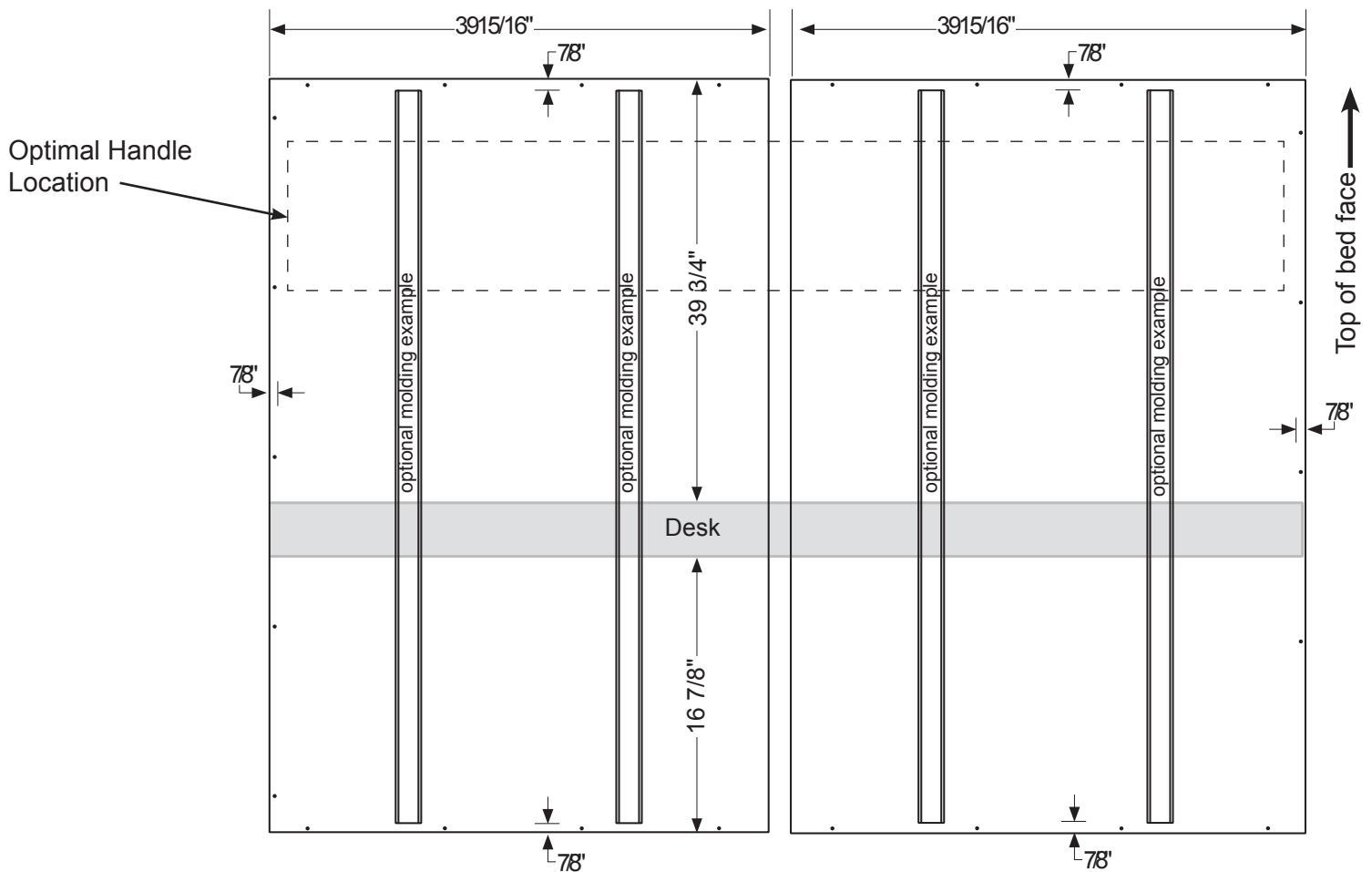
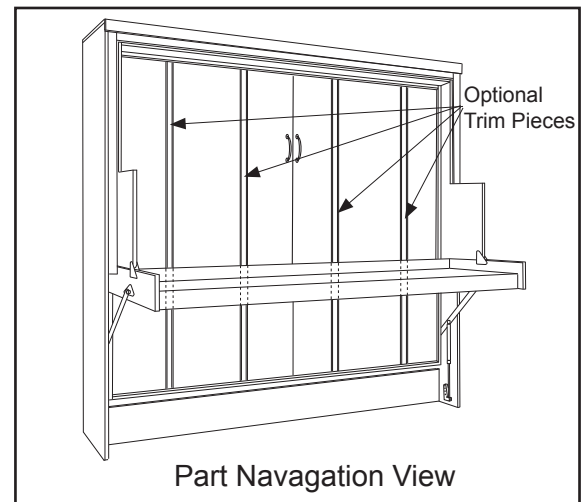

Adding Handles to the Bed Face is recommended and will add a design element as well as ease in opening the bed. As the Face Panel is laid out, map out where you would like the handles to be placed. It is best to position the handles for opening the bed between 12" and 18" from the top of the Face Panels creating better leverage for operating the bed. You can drill the holes for the handle in this step, or choose to install them later whichever suits you best.

#8 x 2" Wood Screw (8)

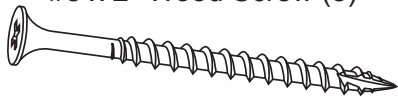

### Step 7: Sideboard Assembly

Locate from Hardwood parts the two Sideboard Fill Attachment part.

With a 11/64" drill bit, drill 4 holes through the 1-3/8" thickness.

Position the Sideboard Fill Attachment on the top front edge of the Sideboard. Glue and Clamp it in place for accuracy and then screw it in place with four 2" wood screws ONLY until the head of the screw is flush with the part..

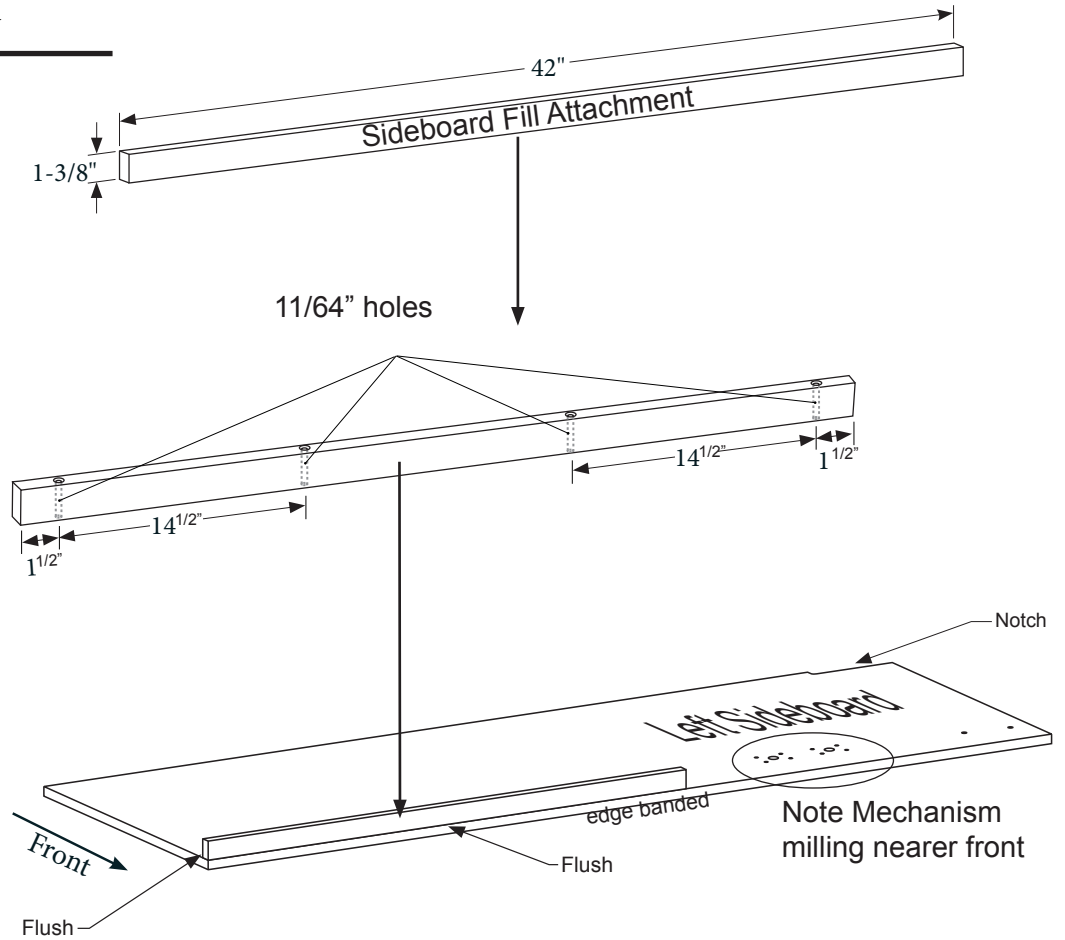

#8 x 1 1/4" Wood Screw (12)



Cut two 13/16" x 13/16" Cleats 20" long and drill opposing 11/64" holes.

Attach the Cleat to the Sideboard using three 1 1/4" wood

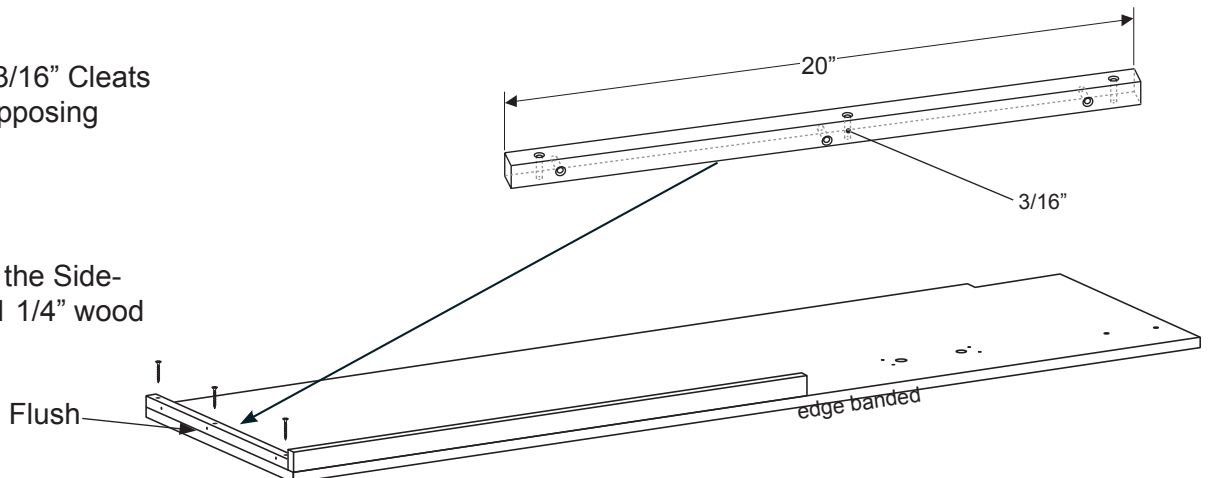

Repeat on Right Sideboard so panels mirror each other.



## #8 x 1 1/4" Wood Screw (6)



### Step 8: Bridge Board

#### Assembly

From Hardwood Parts locate the Bridge Front. Attach it to the bottom front of the Bridge Board verify it is centered leaving 2-1/8" on either end. Then use glue and clamps to hold it accurately in place while it is nailed in place with 1 -1/4" Brad nails.

**Note:** examine the Bridge Board for any bowing. If there is bowing, the crown of the bow in Ply or Hardwood parts should be towards the top. In the illustration below, the Bridge Board is shown upside down.

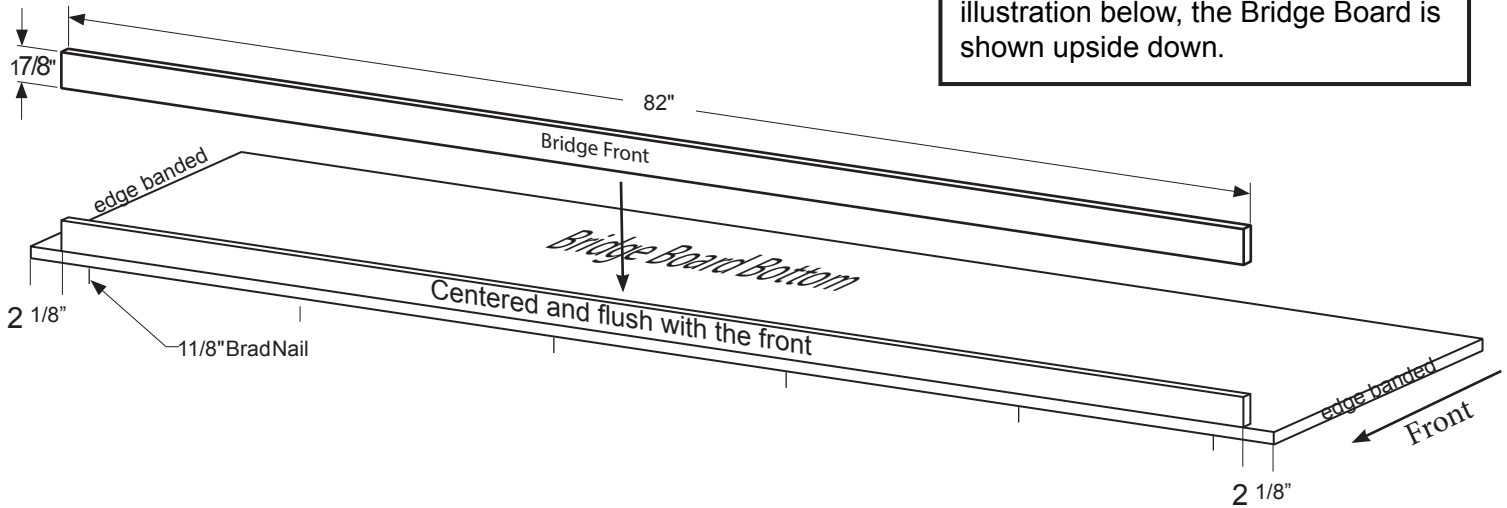

Reinforce the Bridge Front by placing the Bridge Support Cleat (from hardwood parts) behind the Bridge Front and flush end to end. Apply glue to the surfaces and position it against the Bridge Front, and the Bridge Board. Use 1-1/4" Brad nails to anchor it to the Bridge Board and the Bridge Front.

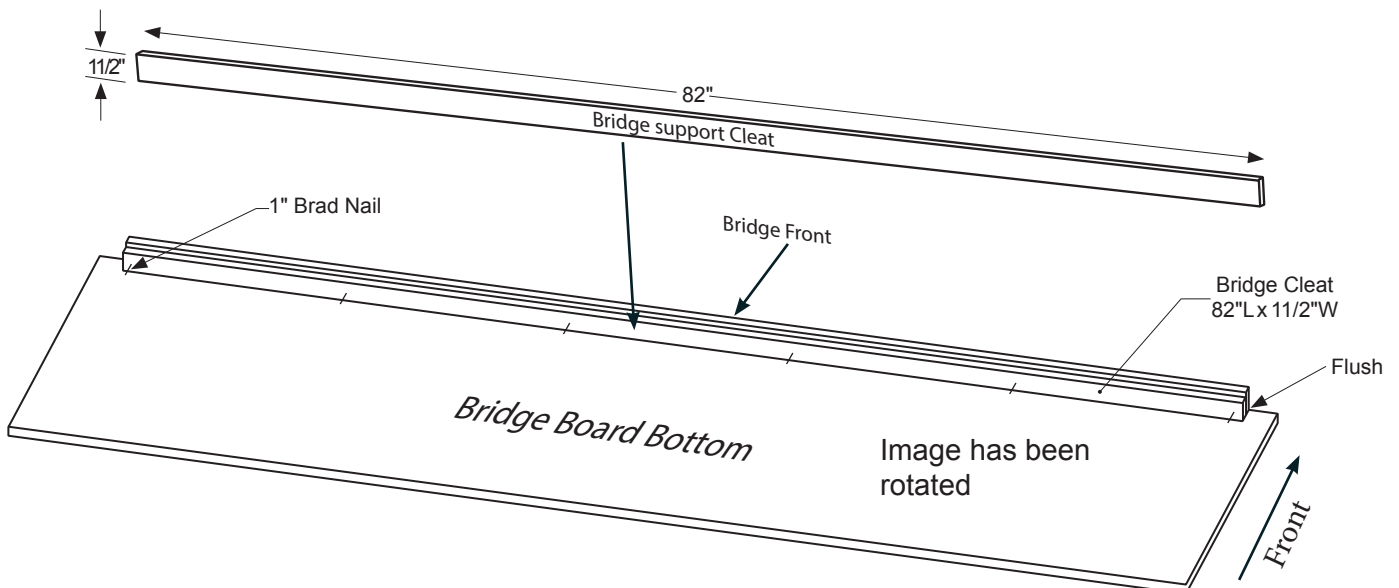



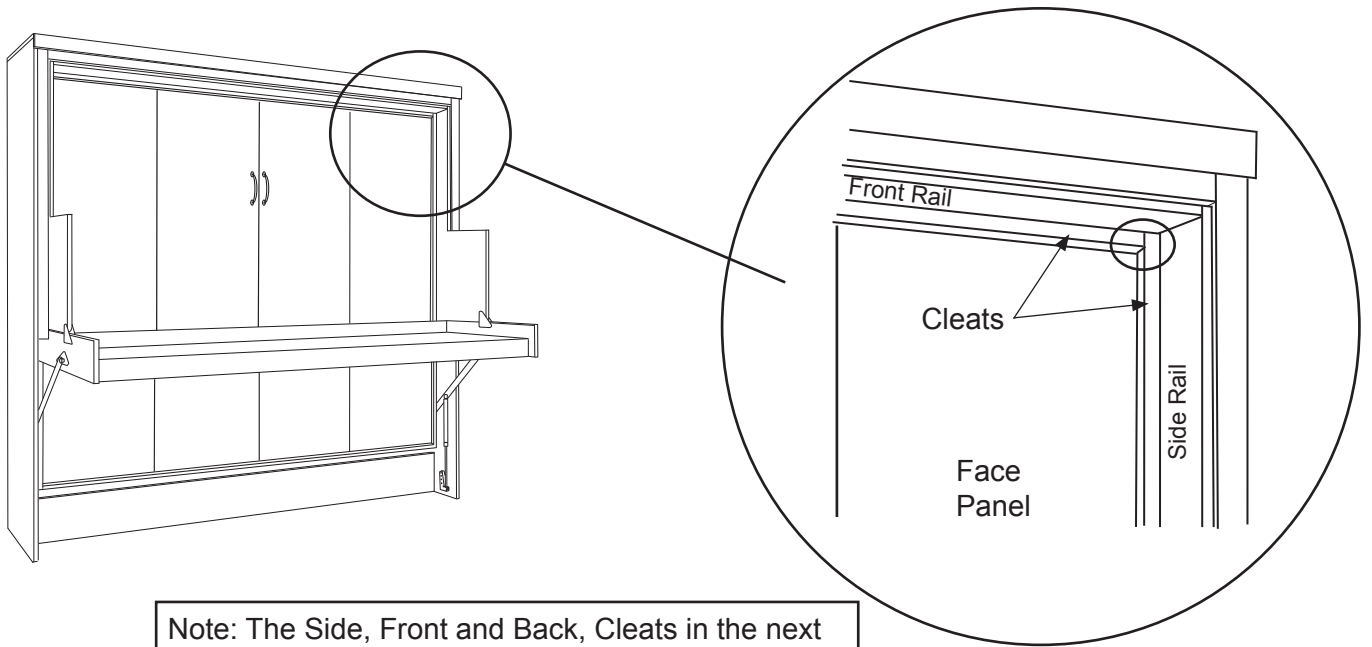

Note: The Side, Front and Back, Cleats in the next two pages will be visible around the parameter of the Bed Face. It is important that the Cleats be the proper length and that they are exactly centered on the rails so they meet up with each other without significant gaps. Consider dry fitting the cleats to verify fit.

#8 x 1 1/4" Wood Screw (6)



### Step 9: Side Rail Assembly.

Run a bead of glue in the dado of the Side Rail then insert the Side Rail Cleat into the dado. Center the Side Rail Cleat in the dado. Use clamps to hold it in place while attaching the Side Rail Cleat to the Side Rails using 1 1/4" brad nails. Reinforce the open end of the Rail by screwing three 1 1/4" wood screws, as illustrated.

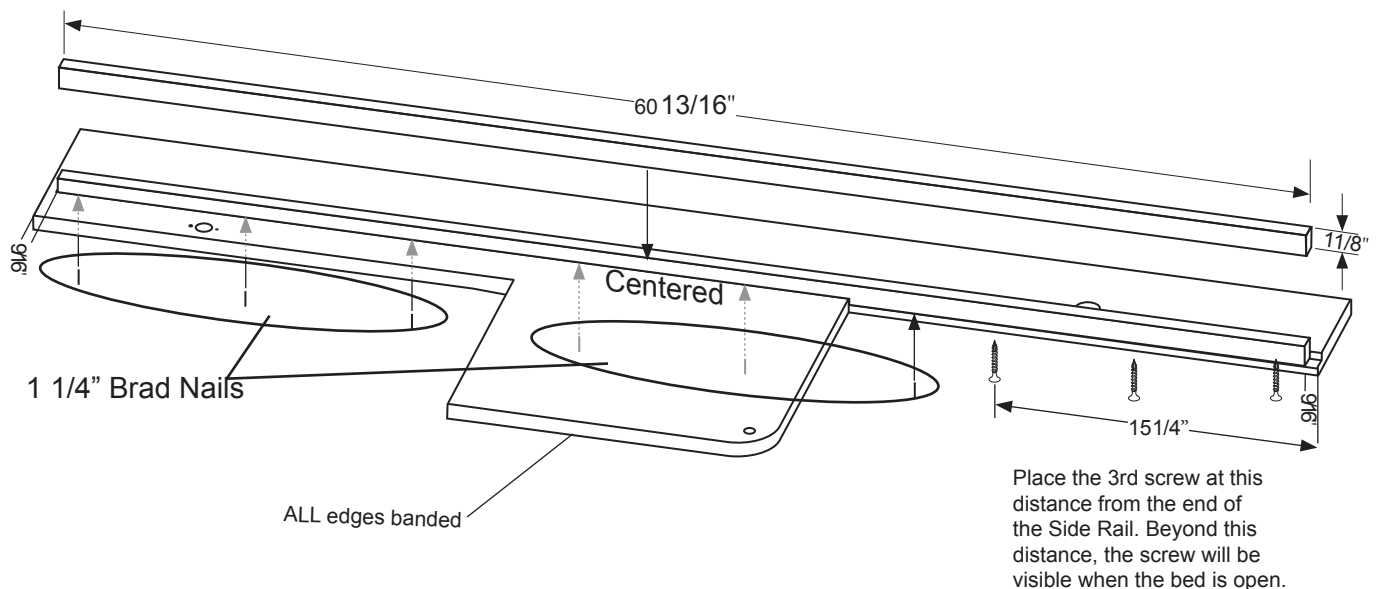

---

#8 x 1 1/4" Wood Screw (4)



---

### Step 10: Front Rail Assembly.

Run a bead of glue in the dado of the Front Rail (wider rail) then insert the Front Rail Cleat into the dado. Center the Cleat leaving about 15/16" on both sides. Clamp the Cleat into the Side Rail and use 1 1/4" Brad nails to anchor it in place.

Note: the Front rail is the most visible rail when the bed is open. Gluing and clamping with several clamps and allowing plenty of time for the glue to dry will allow for far less or even no Brad nails if it is glue sufficiently.

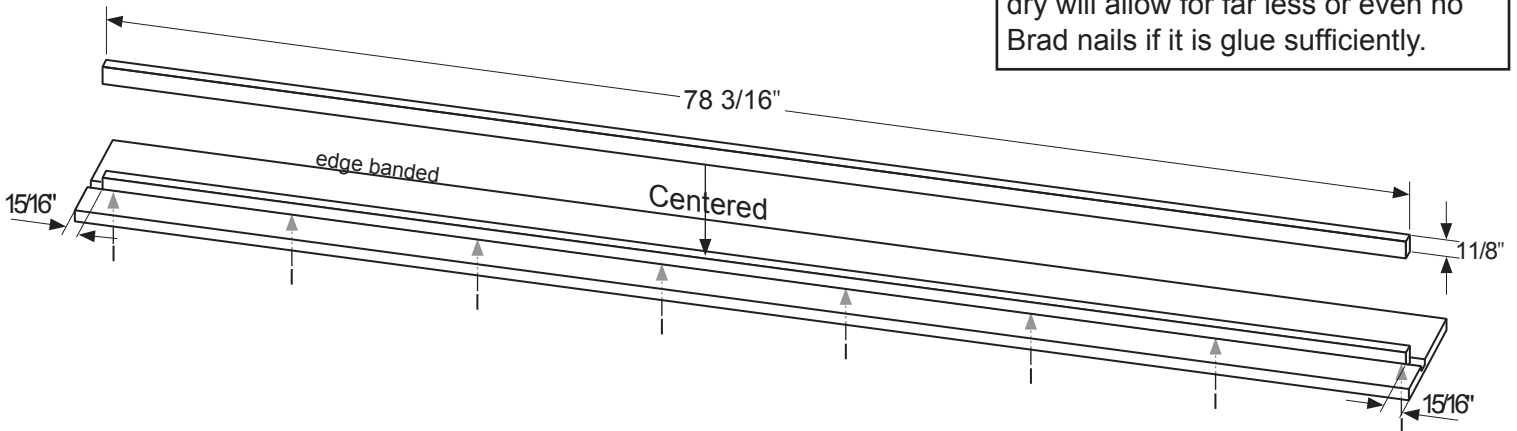

---

#8 x 1 1/4" Wood Screw (6)



---

### Step 11: Back Rail Assembly.

Run a bead of glue in the dado of the Back Rail (narrower rail) now place the Back Rail Cleat into the dado at the bottom Inner Rail. Center the Side Rail Cleat leaving about 15/16" on both ends. Use clamps to hold it in place and then use 1 1/4" wood screws evenly dispersed to anchor it in place.

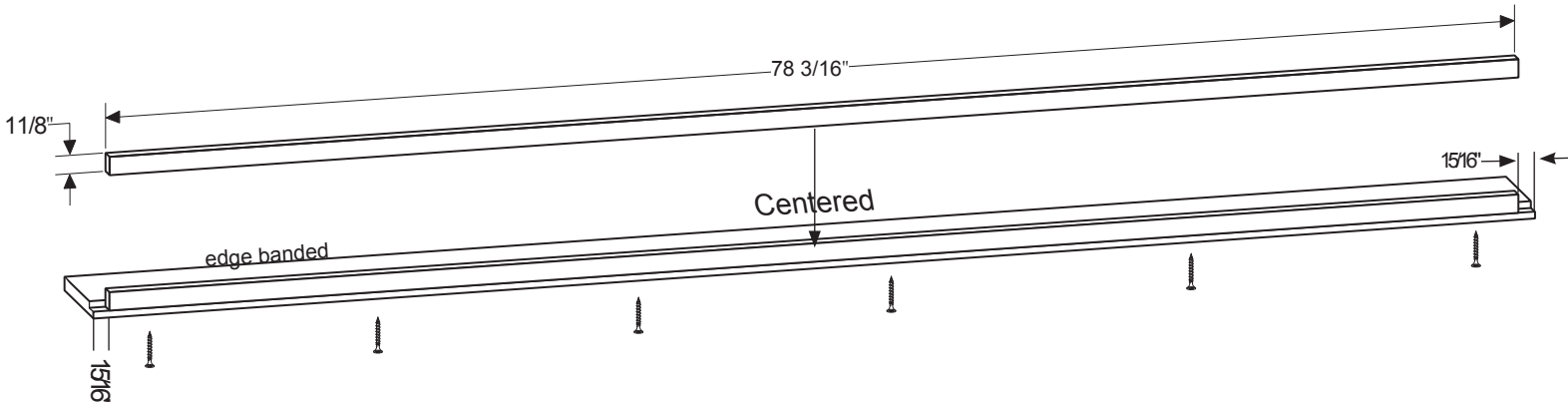

## Step 12: Desk Assembly

NOTE: Examine the Desk Panel to determine the side that you would like to use as the desk's surface.

#8 x 1 1/4" Wood Screw (8)



#8 x 2" Wood Screw (12)

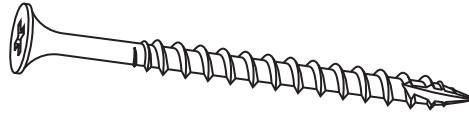

#8 x 2 1/2" Wood Screw (7)

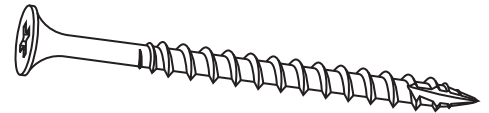

Locate the Desk Front (from hard wood parts). Drill seven 11/64" holes evenly spaced through the 1-7/8" thickness on the Desk Front piece. Countersink the holes so the head of the screw is flush with the surface.

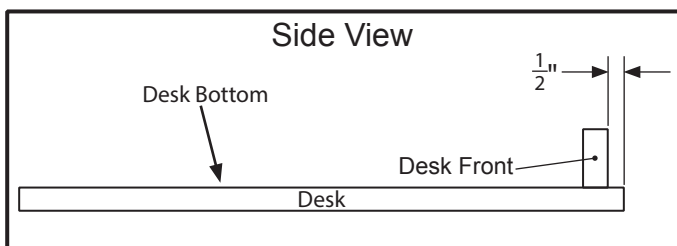
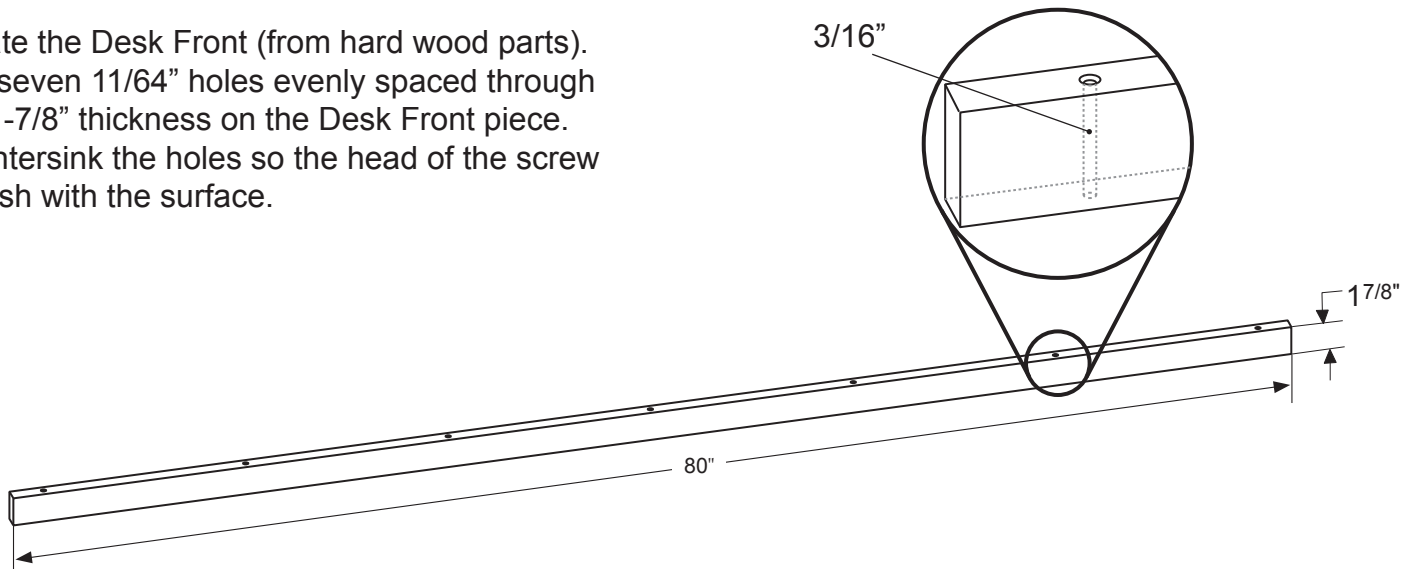

Attach the Desk Front to the Desk Panel bottom by clamping it in place back 1/2" from the Desk panel's front and then screwing it in place using the 2 1/2" wood screws. Only until the head of the screw is flush. Do not over counter sink the screw.

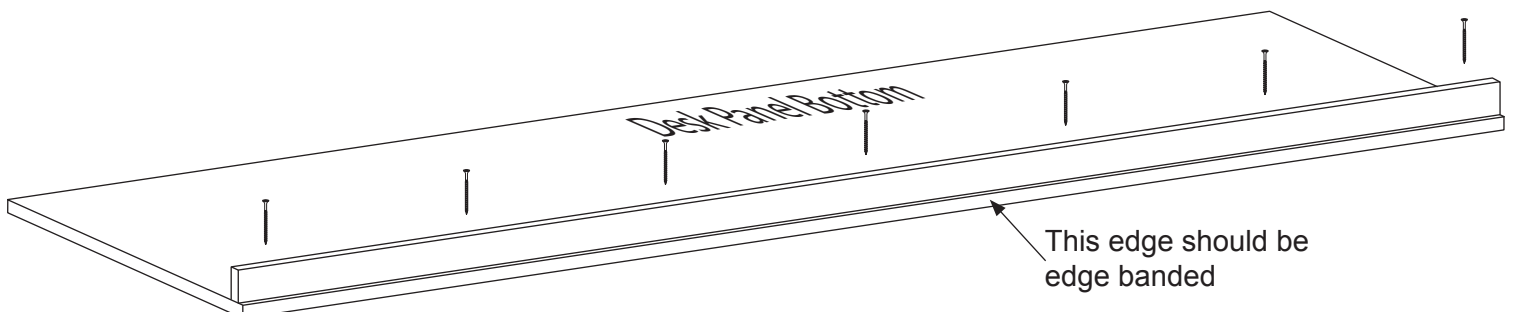

## Step 12: Desk Assembly Cont.

Reinforce the Desk using the Desk Support from hardwood parts. Apply glue to the back of the Desk Front and the bottom of the Desk Panel. Position directly behind the Desk Front and flush on the ends. Use 1 1/4" Brad nails to anchor in place.

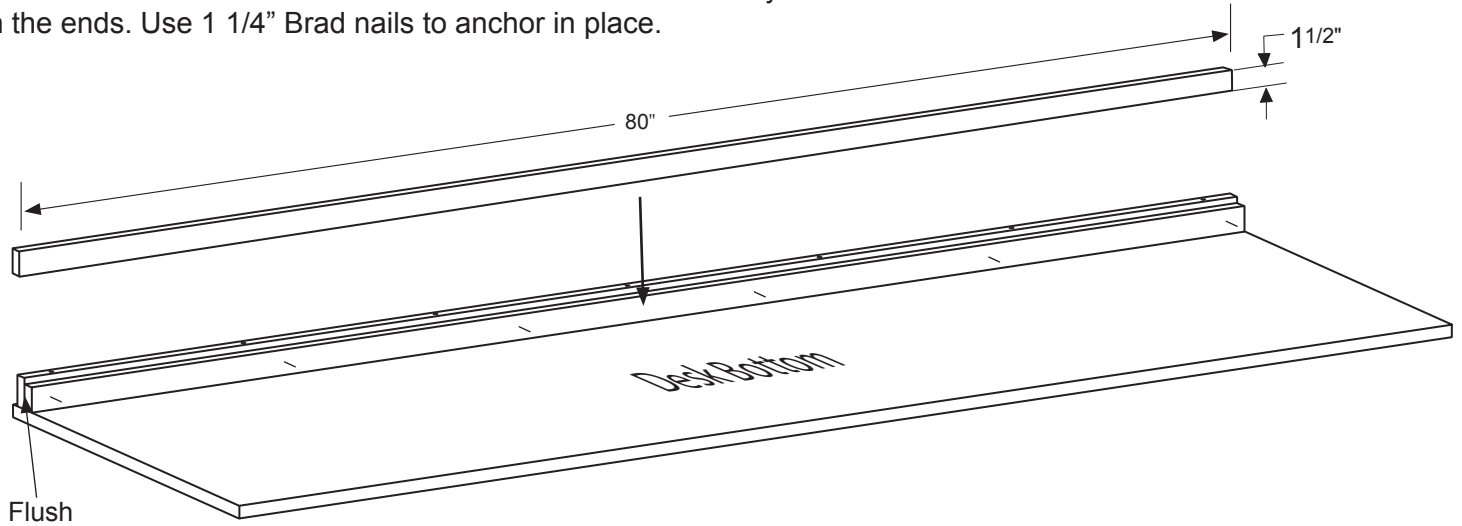

#8 x 1 1/2" Wood Screw (6)



Locate the Desk Back. Drill a series of six, 11/64" holes evenly spaced and in the exact middle of the panel.

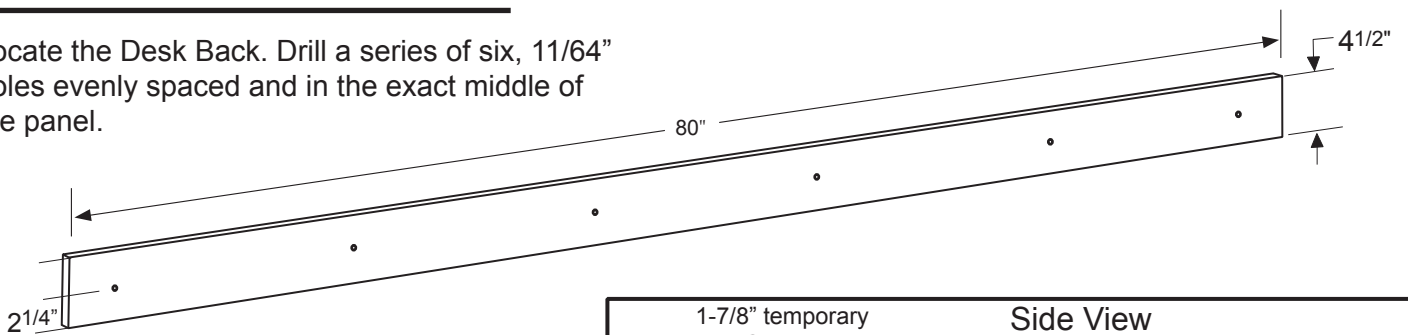

Attach the Desk Back to the Desk Panel using six 1-1/2" wood screws in the pre drilled holes.

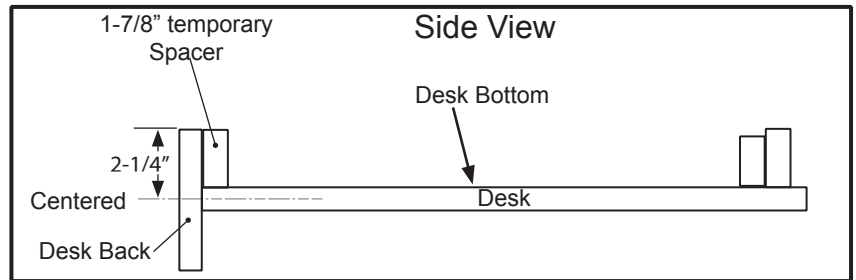

Note: It is important that the Desk Back is attached to the center of the 3/4" Desk Panel. Use a 1-7/8" spacer to get the Back exactly centered.

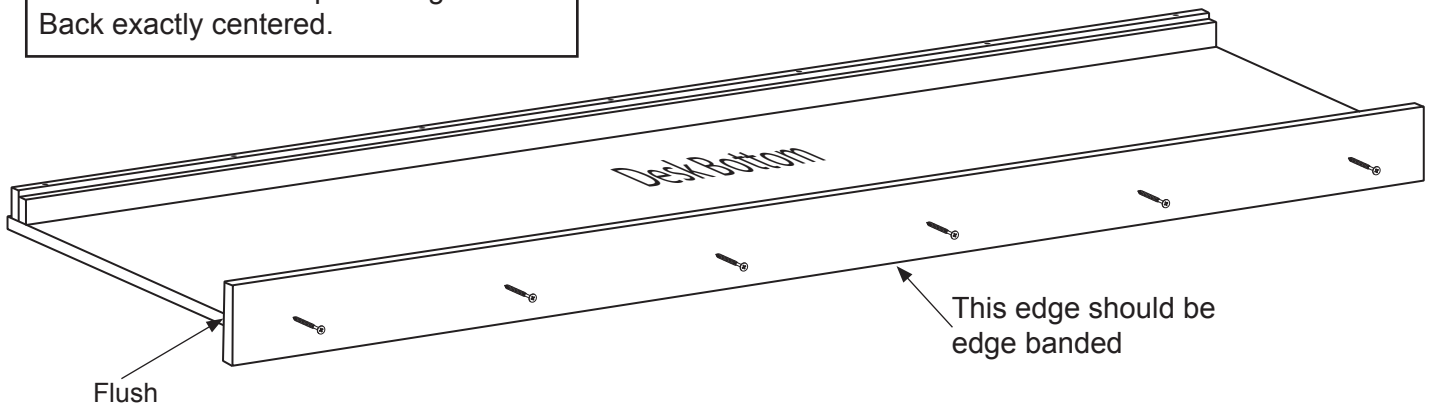

## Step 12: Desk Assembly Cont.

Locate the 2 Desk Ends and drill holes through the panels as indicated.

All Side Should be Edge Banded

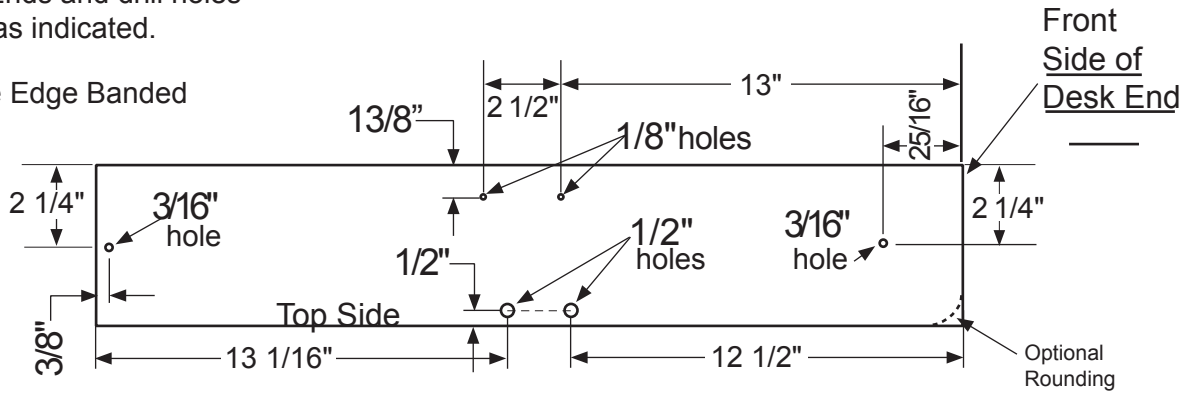

#8 x 2" Wood Screw (4)

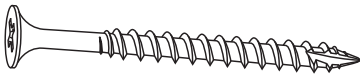

Attach the Desk Ends to the sides of the Desk using two 2" wood screws, per side, as illustrated.

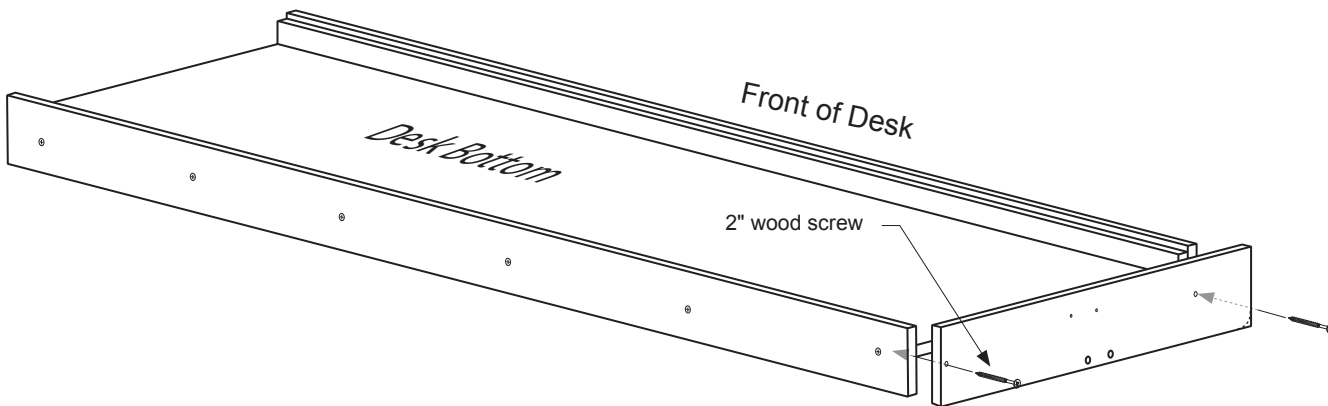
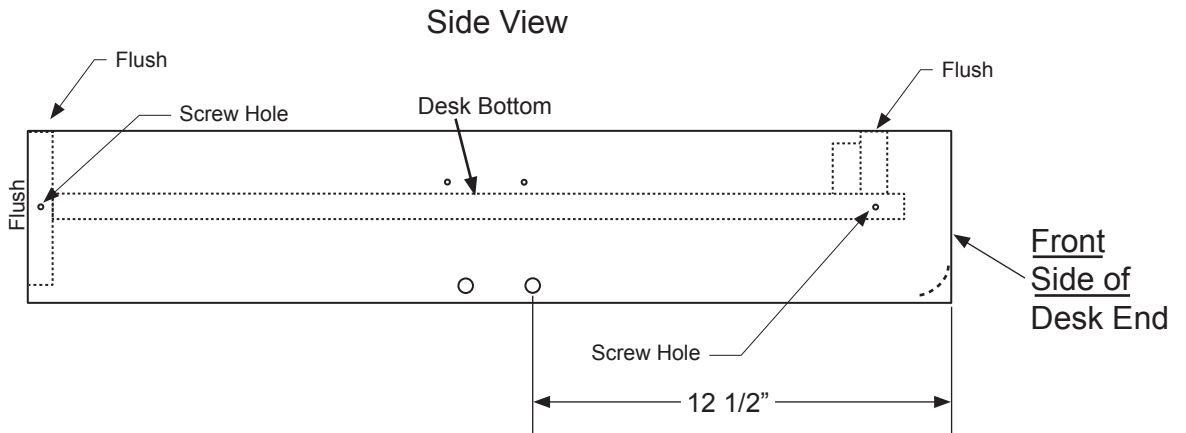

#8 x 1 1/4" Wood Screw (8)



#8 x 2" Wood Screw (6)

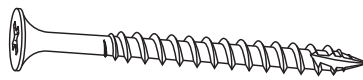

## Step 12: Desk Assembly Cont.

Drill 11/64" holes in the Desk Cleats (From Hardwood parts) as shown. Use a countersink bit so the head of the screws are flush with the surface.

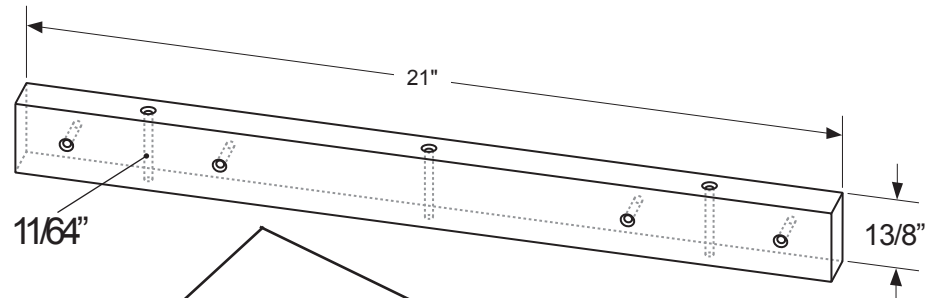

Reinforce the Desk Ends by attaching the Desk Cleats to the Desk and Desk Ends. Use glue, 1 1/4" wood screws, and 2" wood screws.

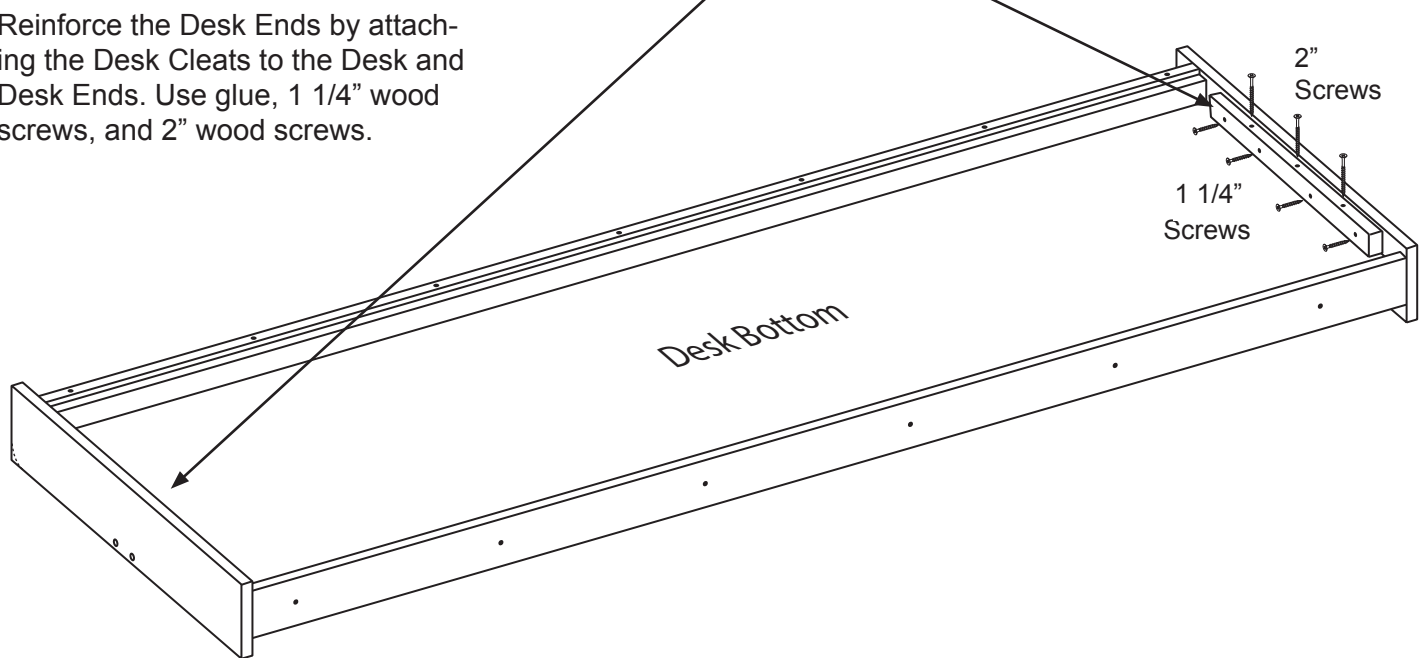

#8 x 1 1/4" Wood Screw (4)



## Step 13: Bed Stops

Attach Bed Stops to the Bed Stop Supports using 1-1/4 screws as shown, through 11/64" pre-drilled holes. Then pre drill 2 holes through the Bed Stop Supports.

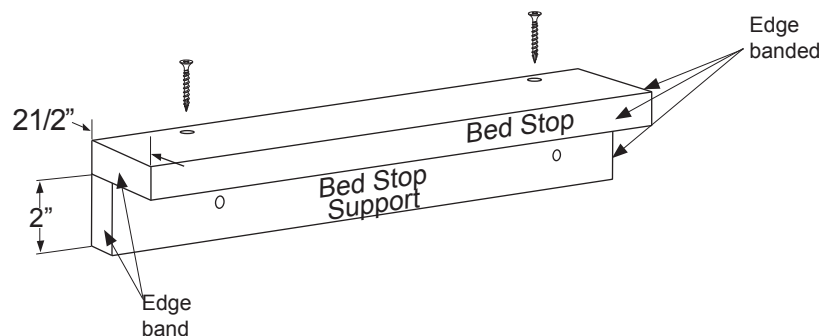



## Step 14: Bed Components

Cut a set of solid wood Cleats for the Headboard and Stretcher. Drill  $1\frac{1}{64}$ " holes as shown.

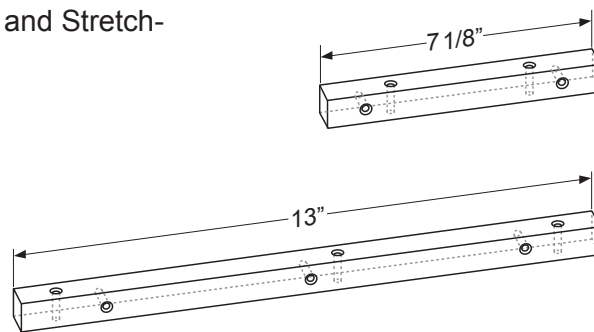

#8 x 1 1/4" Wood Screw (14)



Attach Cleats to both ends of the Headboard and Front Stretcher as shown.

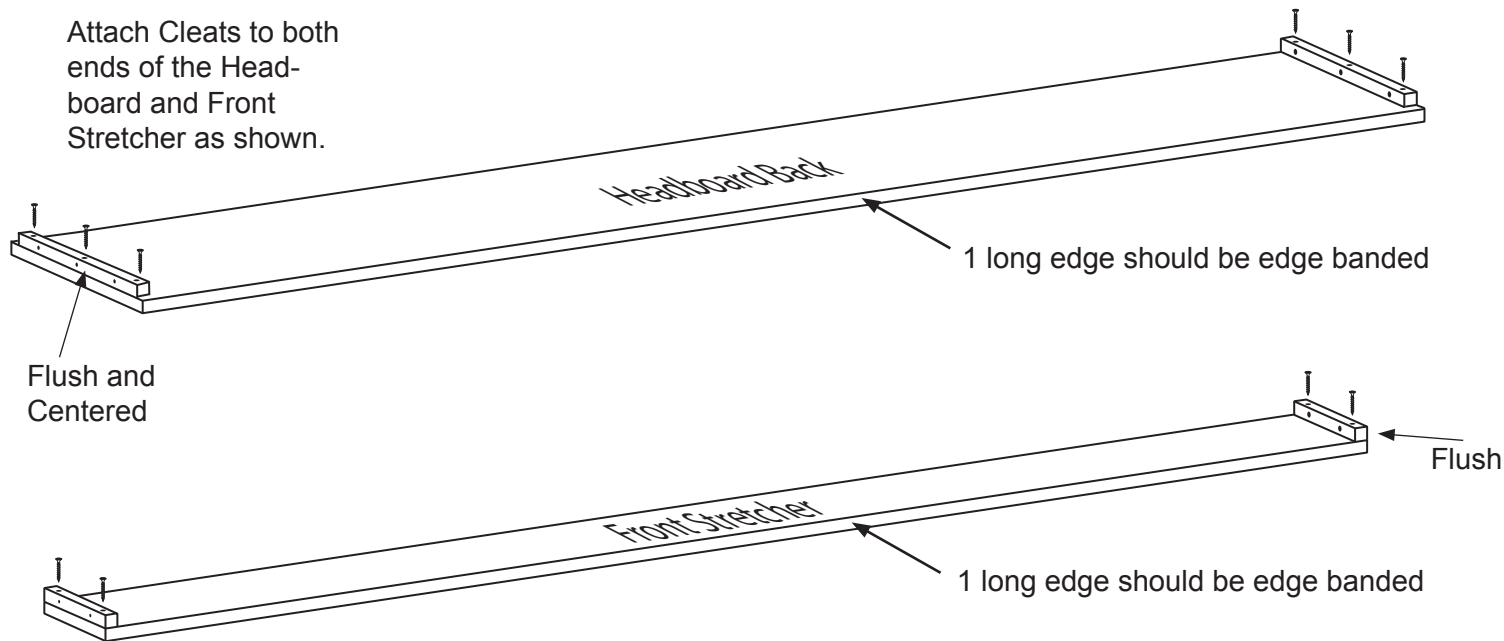

## Step 15: Mattress Stiffener

Drill two rows of holes in the Mattress Stiffener with a  $\frac{3}{16}$ " bit at approximately 2" apart.

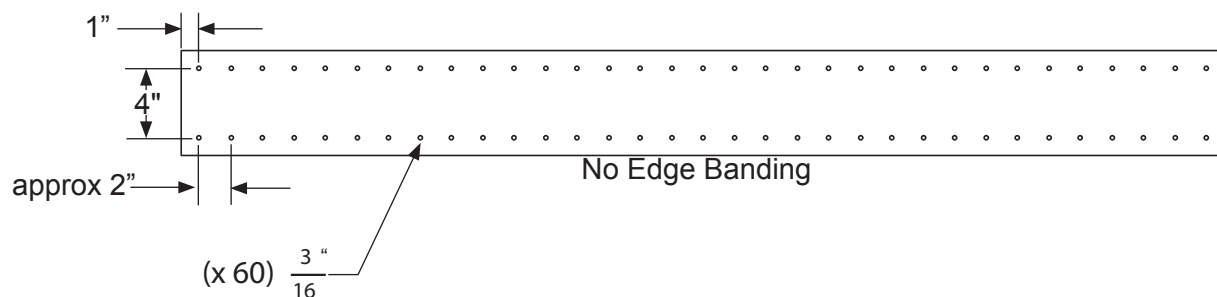

# Step 16: Finishing Parts

Prepare the surfaces to be finished, then apply the desired finish to the parts as illustrated.

## Headboard:

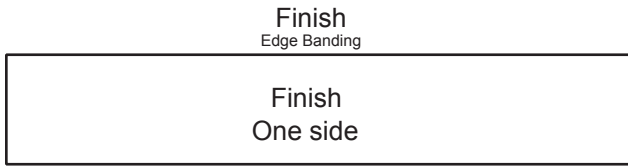

## Stretcher:



## Desk:

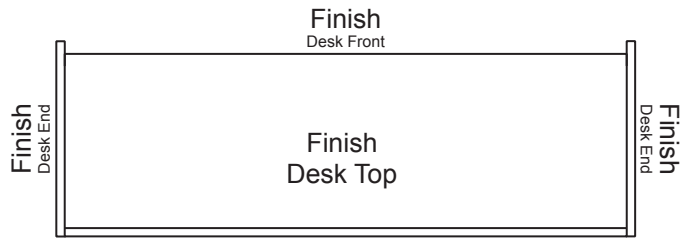

## Bed Stop:

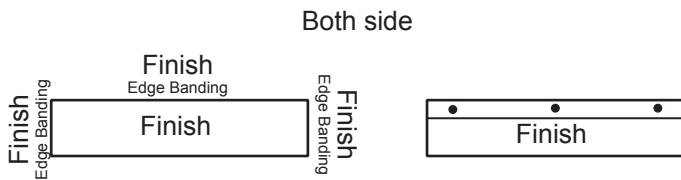

## Sideboard:

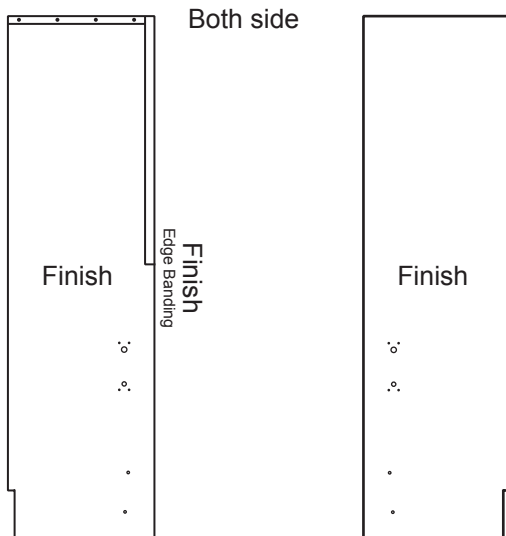

## Bridge Board:

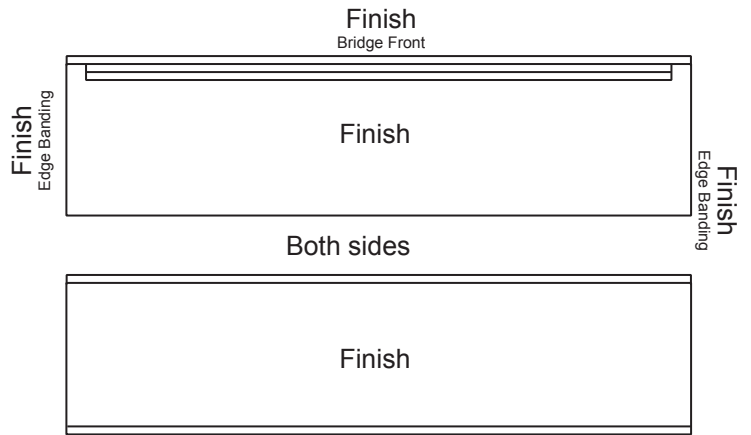

## Front Rail:

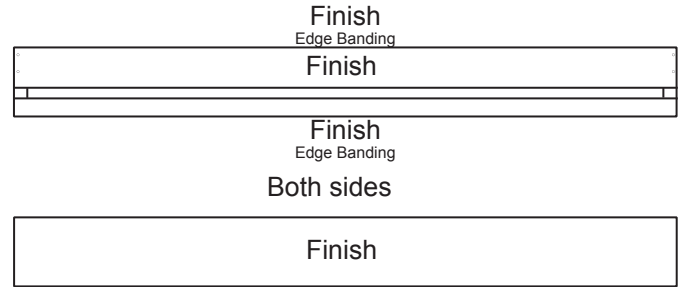

## Back Rail:

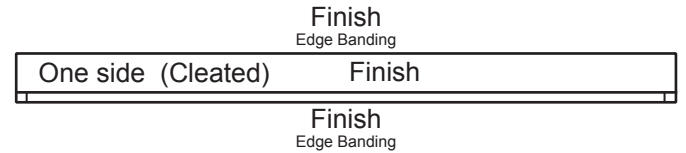

## Side Rail:

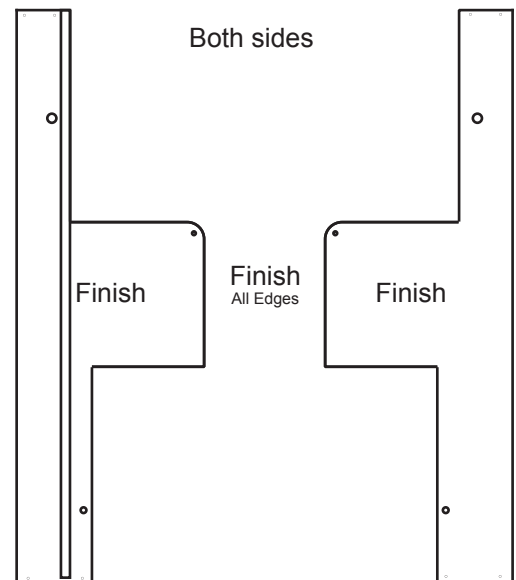

## Step 16: Finishing Parts Cont.

Bed Face panels:

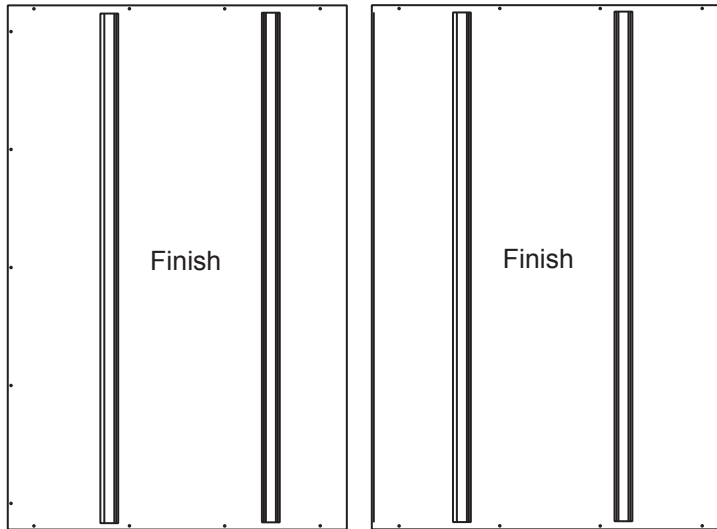

## Assembly and Installation of Bed

The next section of the instructions will be to assemble the Bed Unit. The assembly of the Bed Unit should be done in the room the bed will be installed, and near to the wall the bed will be anchored to.

#8 x 1 1/4" Wood Screw (6)



### Step 16: Bridge Board installation

Lay the Sideboards and the Bridge Board down on the ground and attach the Bridge Board to the top of the Sideboards, as illustrated.

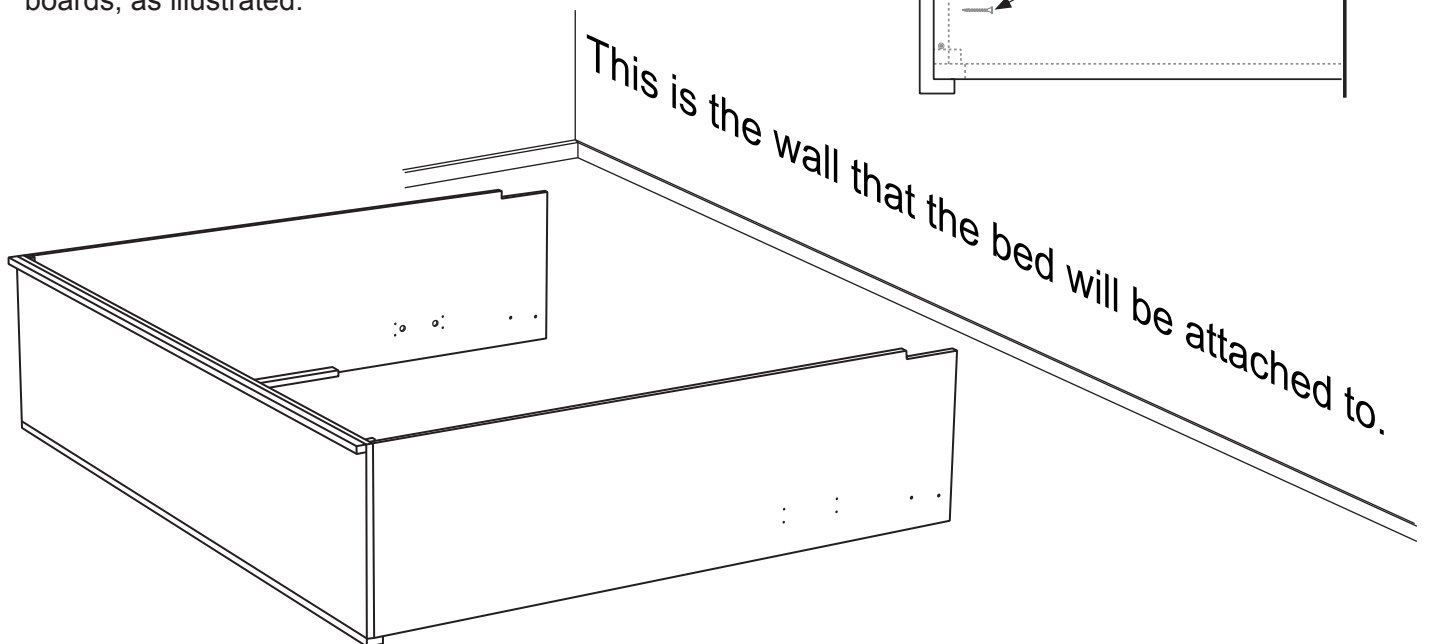
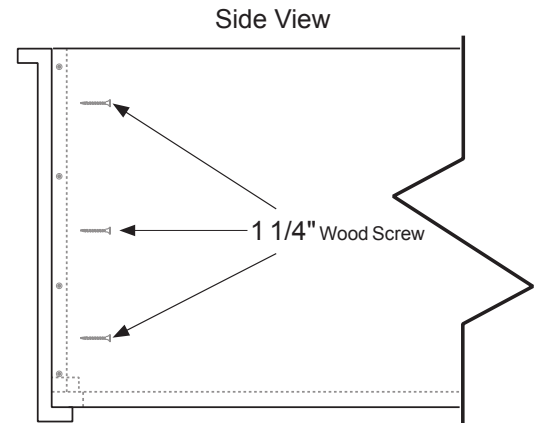

#8 x 1 1/4" Wood Screw (6)

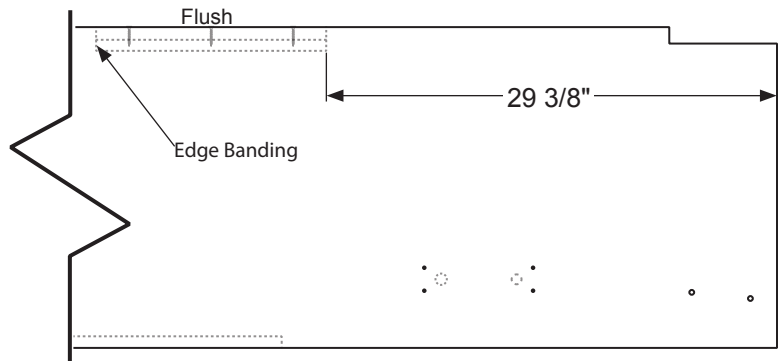

### Step 17: Headboard Installation

Attach the Headboard to the Sideboards using six 1 1/4" wood screws

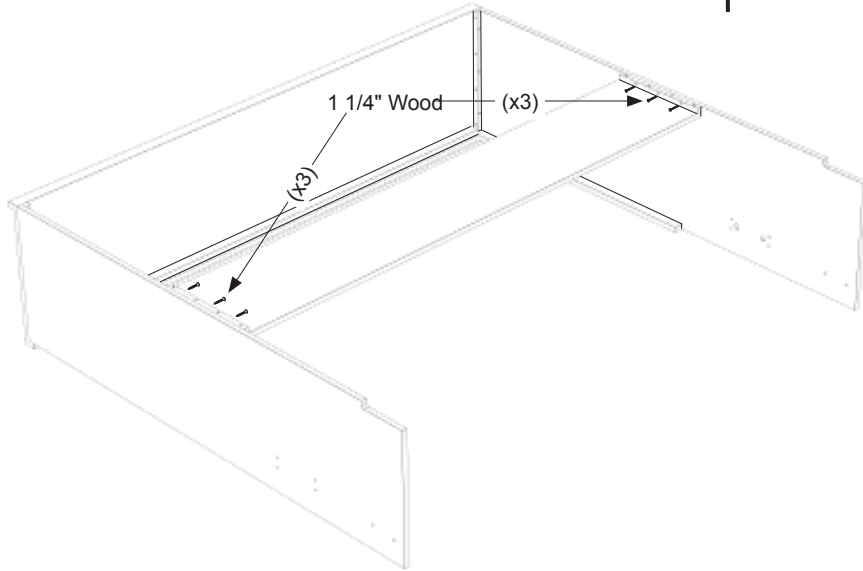

#8 x 1 1/4" Wood Screw (4)



### Step 18: Stretcher Installation

Attach the Stretcher to the Sideboards using four 1 1/4" wood screws

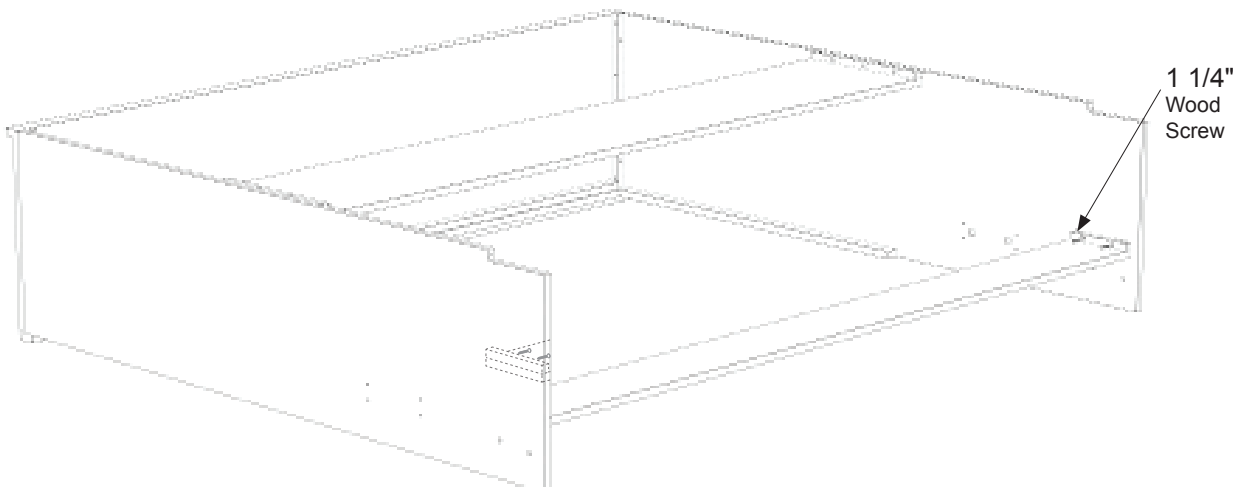
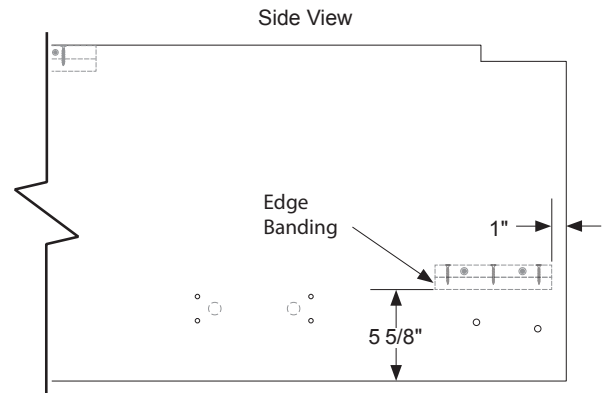

#8 x 1 1/4" Wood Screw (4)



### Step 19: Bed Stop Installation

Attach the Bed Stops to the Sideboards, using four 1 1/4" wood screws. Bed Stops should be flush with the back of the Side Board and pushed up against the Cleats.

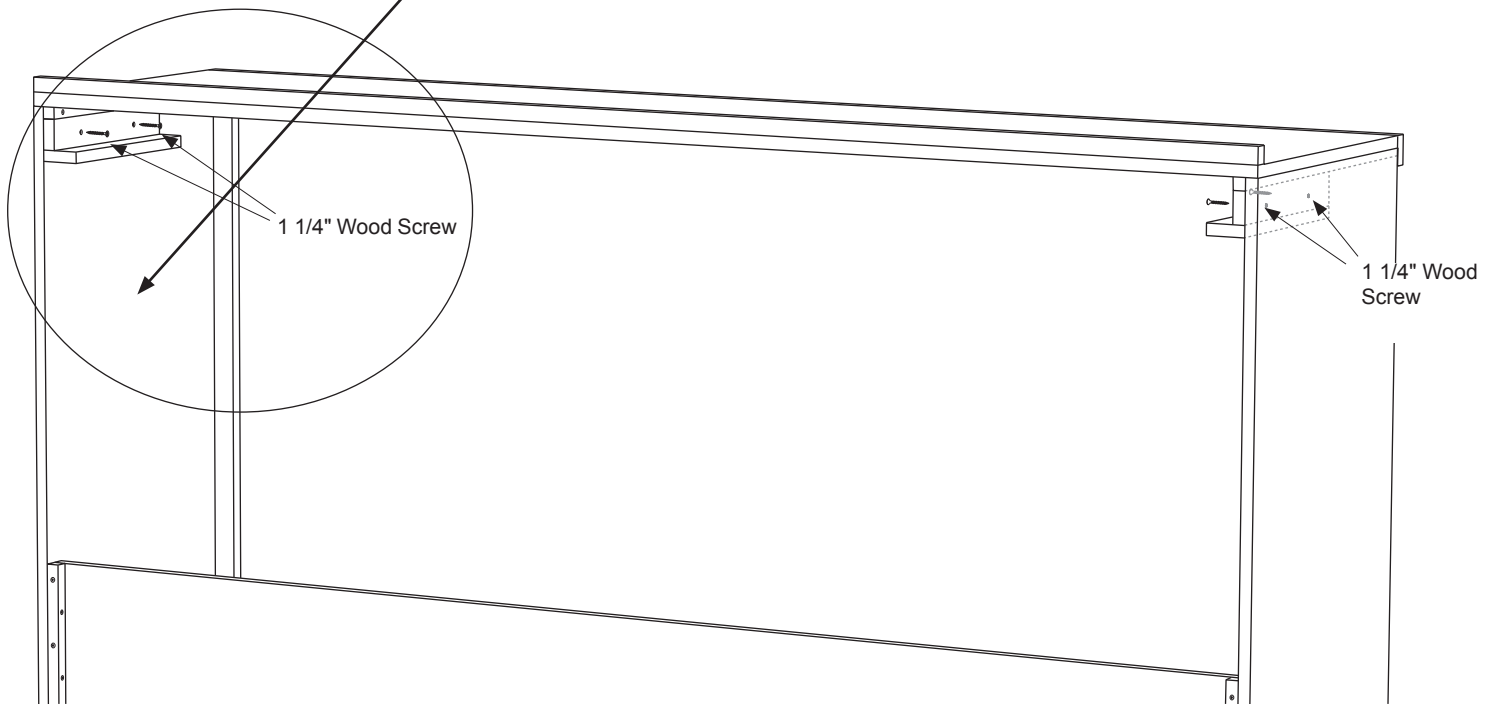
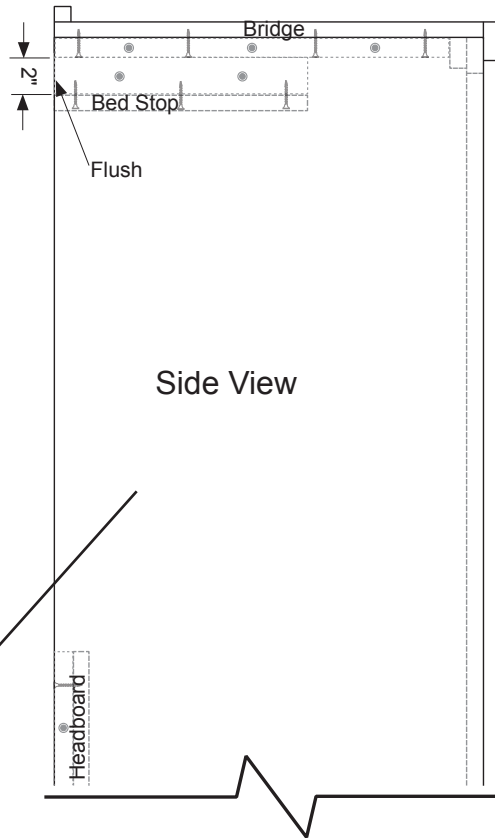

WARNING! FAILURE TO PROPERLY ANCHOR THE CABINET TO THE STUDS IN YOUR HOME COULD CAUSE SEVERE PERSONAL INJURY OR DEATH. CALL TECHNICAL SUPPORT AT 866-725-6401 IF YOU HAVE ANY QUESTIONS.

#10 x 3 1/2" Washer Head Screws (3)

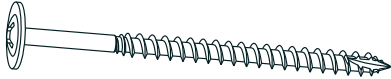

Included in Mechanism Box

### Step 20: Anchoring the Bed to the Wall

Stand the Bed Cabinet Surround up, and place it against the wall for installation. Use a step ladder to reach above the Bridge Board. Using a stud finder, locate 3 studs within the length of the Bridge Back. Mark the studs with a light pencil mark.

After three studs have been located, use a 1/4" drill bit to drill 3 holes, **only through the Bride Back**, corresponding to where the studs are located.

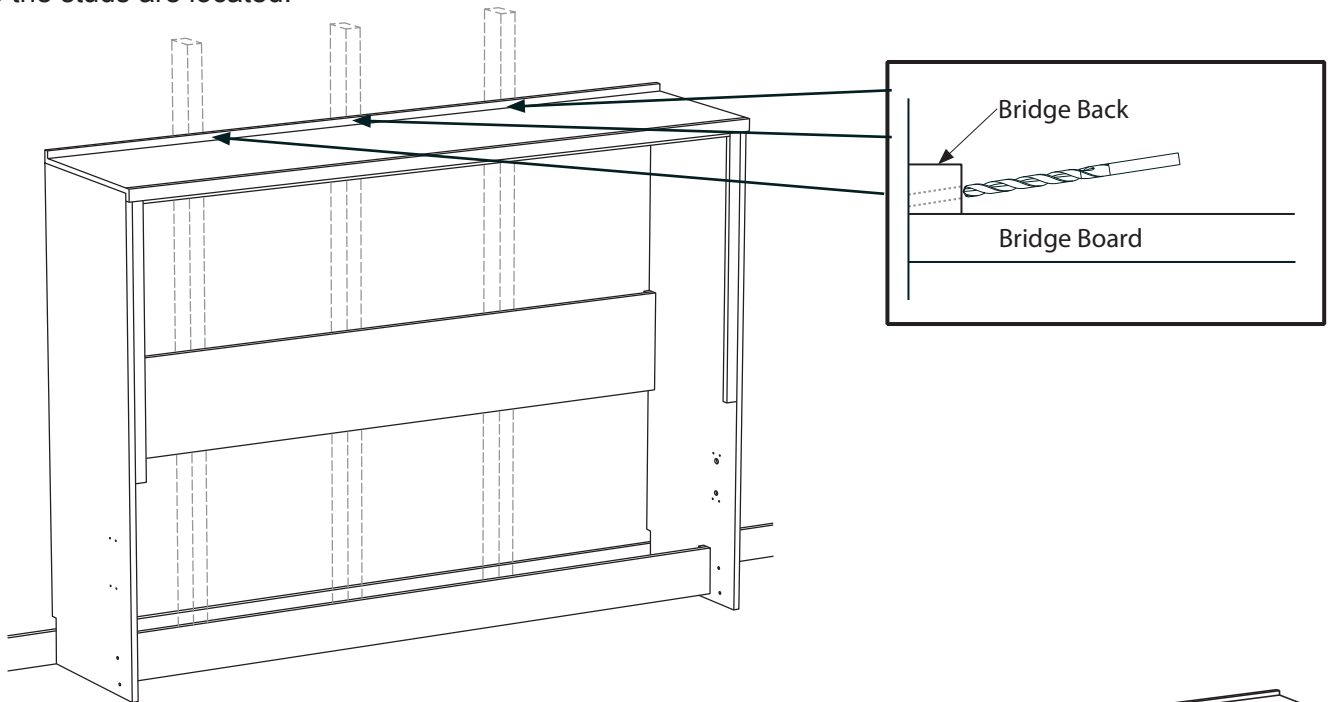

Anchor the cabinet to the wall using three 3 1/2" Washer Head Screws.

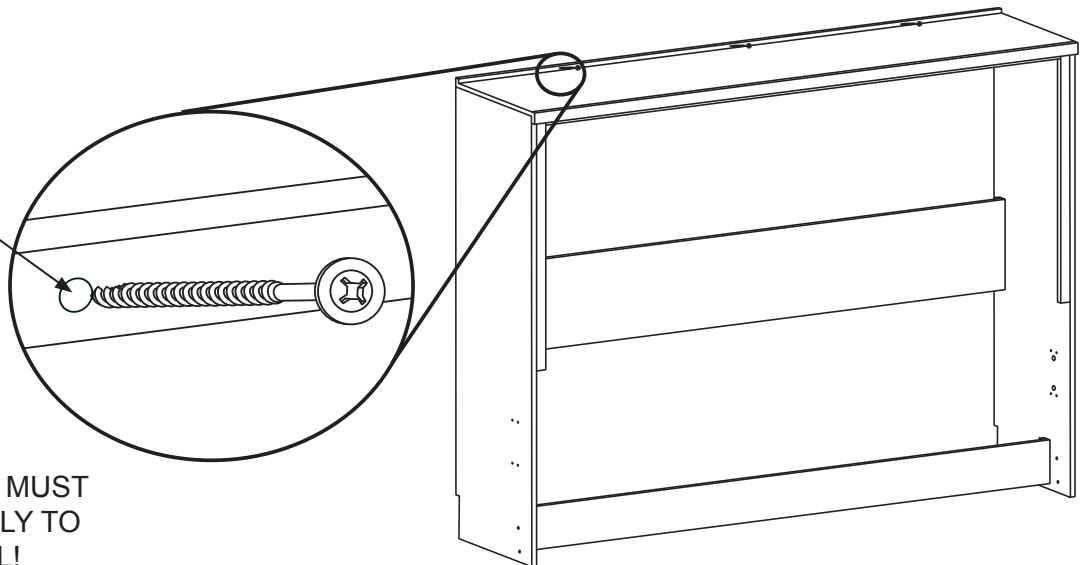

WARNING THE CABINET MUST BE ANCHORED SECURELY TO THE STUDS IN THE WALL!

5/8" Machine Screw (8)    3/16" Barrel Nut (8)    #12 X 3/4" Wood Screw (8)

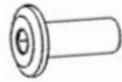
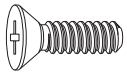

Included in Mechanism Box

### Step 21: Attaching Lift Mechanism

Attach the Lifting Arms to the Sideboards using 5/8" machine screws, and 3/16" barrel nuts in the upper 2 and lower 2 holes. Then use #12 Wood screws in the four holes in the center.

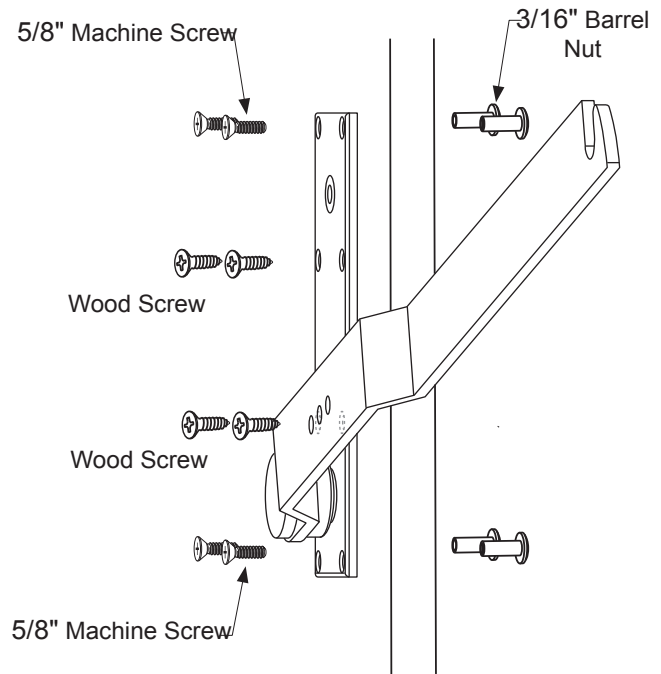
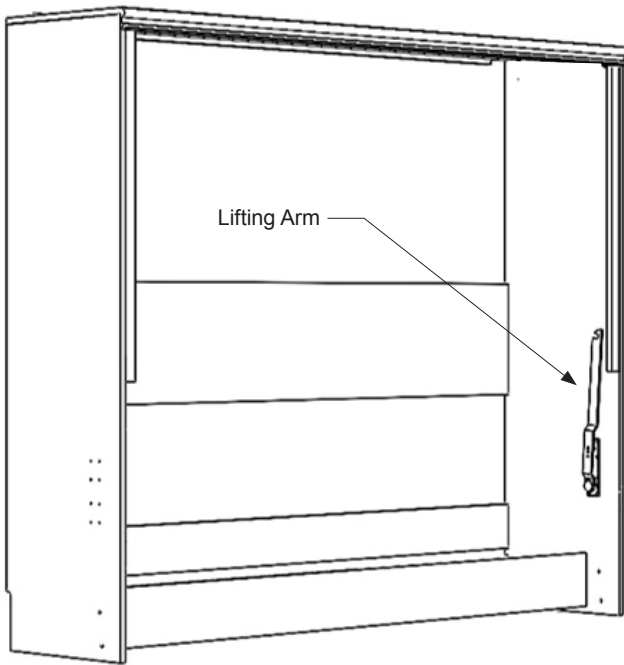

Lower Bracket (2)

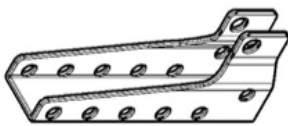

Clevis Pin (2)



Cotter Pin (2)



Included in Mechanism Box

Set the Piston in place in the Lower Bracket, as illustrated. Insert the Clevis Pin through the Lower Bracket and Piston. Once the Clevis Pin is in position, secure it in place with a Cotter Pin.

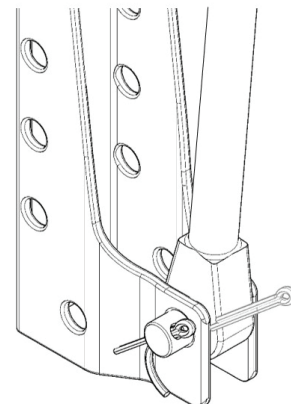
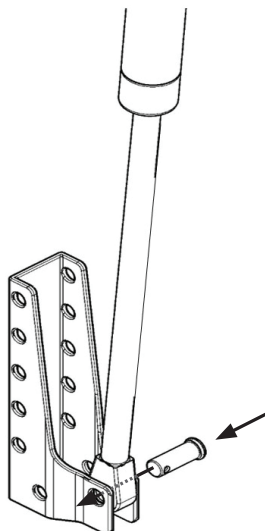

1/4 - 20 x 40 Furniture Screw (4)



1/4" Barrel Nut (4)

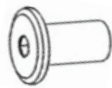

Included in Mechanism Box

### Step 21: Attaching Lift Mechanism Cont.

Maneuver the Piston and Lifting Arm until the socket of the Piston lines up with the Ball Stud on the Lifting Arm. Once aligned, push the parts together until the Ball Stud snaps into the socket of the Piston. When done correctly, there will be a clicking sound when the parts lock together.

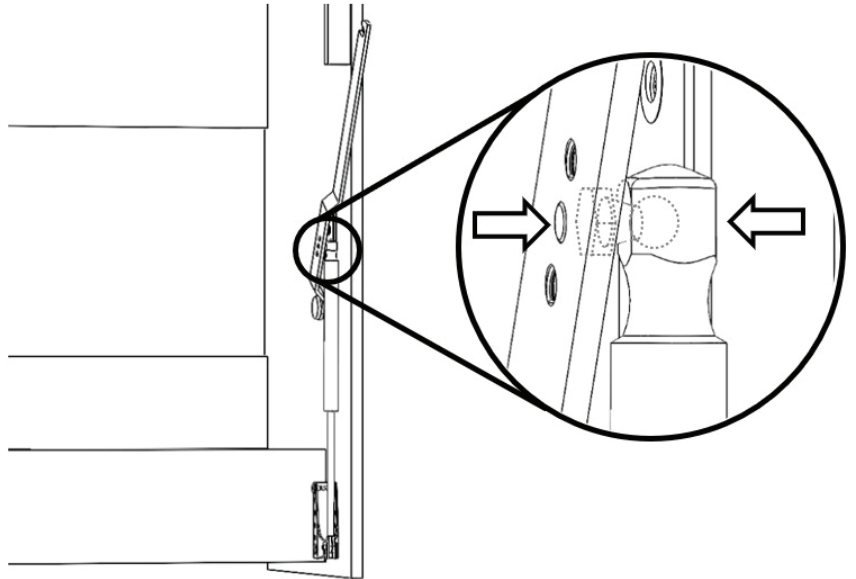

Attach the Lower Bracket to the Sideboards using four sets (two per side) of 40mm furniture screws, with 1/4" barrel nuts.

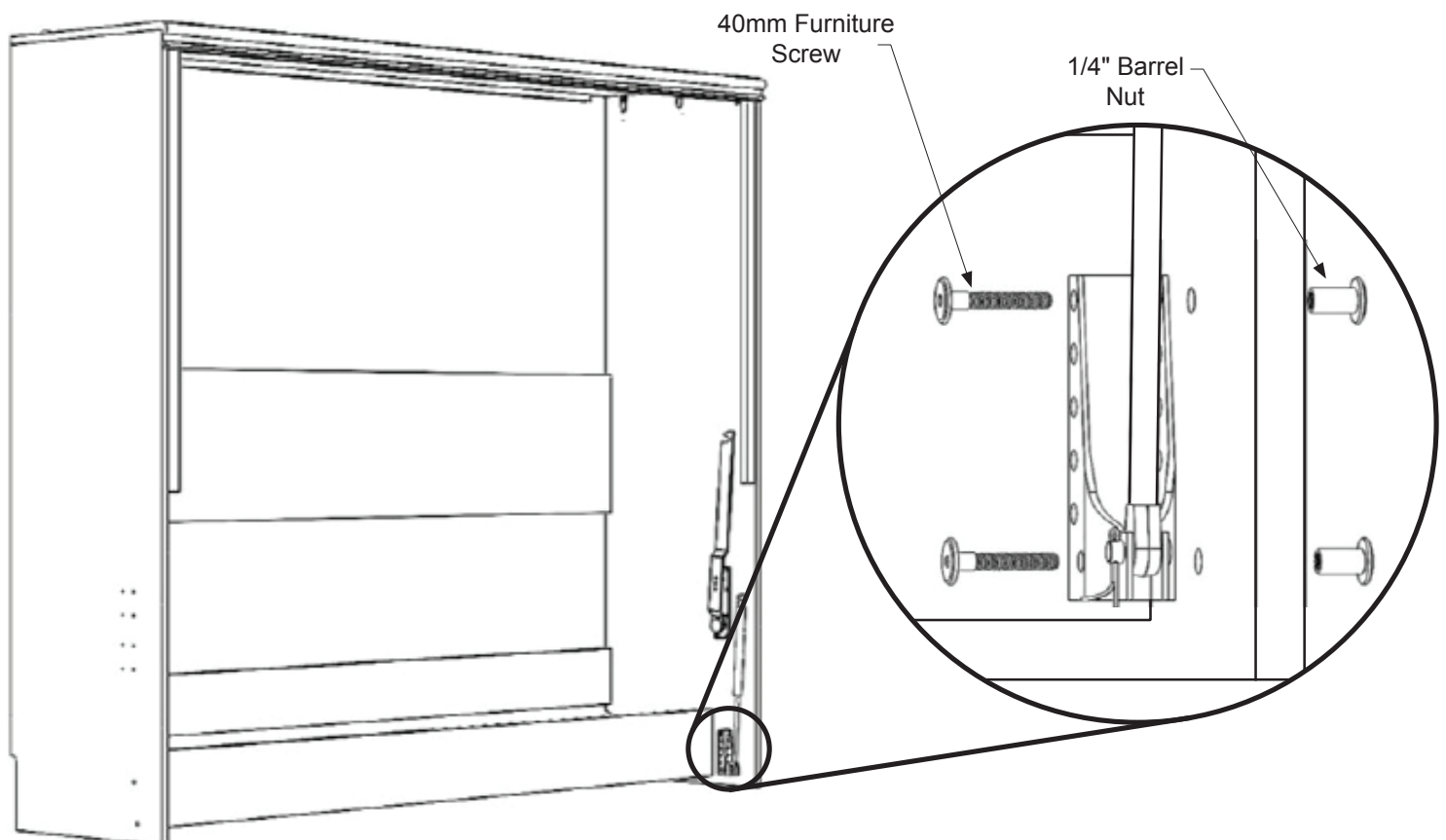



Thin Triangle Plate (4) 6.5mm Machine Screw (8)

Threaded Steel Barrel (4)

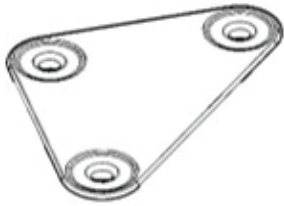

Included in Mechanism Box

### Step 21: Attaching Desk Hardware

Attach the Thin Triangle Plates to the Desk, as shown below.  
*Do not fully tighten the machine screws at this point.*

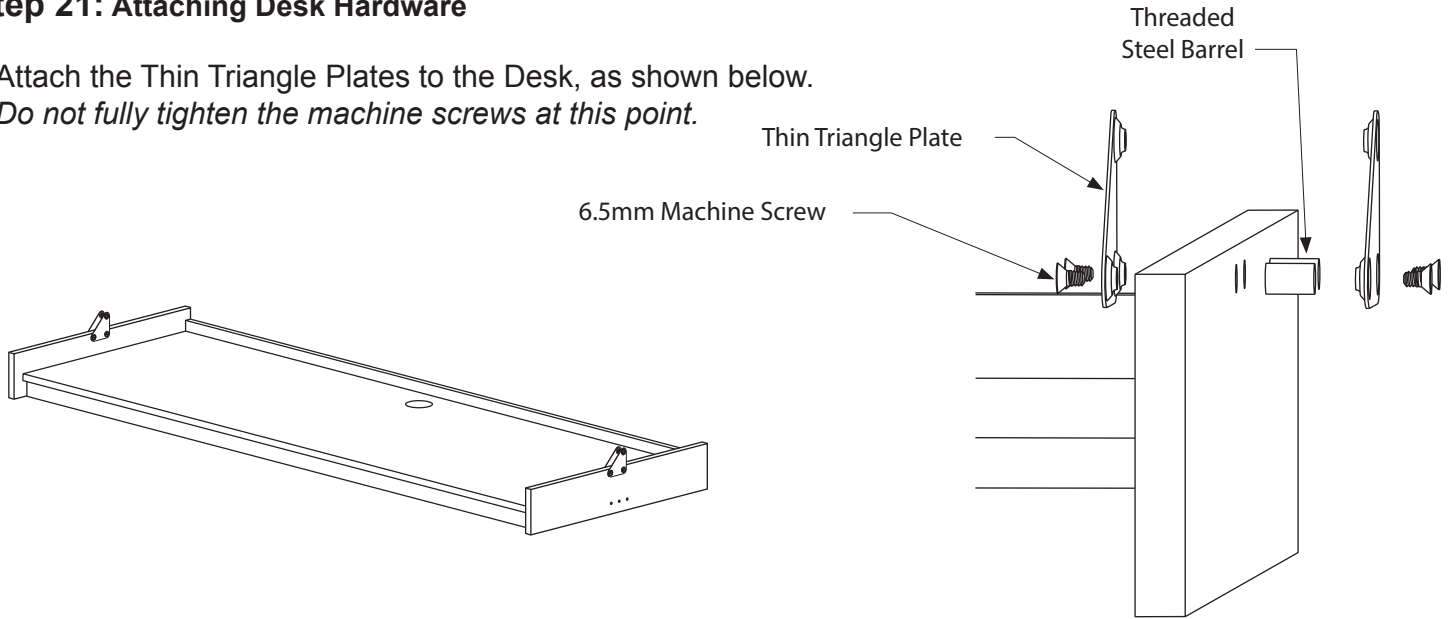

#8 x 1 1/2" Wood Screw (8)

#8 x 2 1/2" Wood Screw (7)

Heavy Triangle Plate (2)

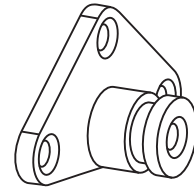
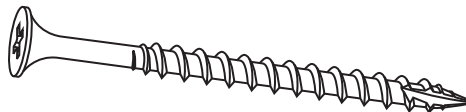

Attach the Heavy Triangle Plate to the sides of the Desk using the wood screws indicated.

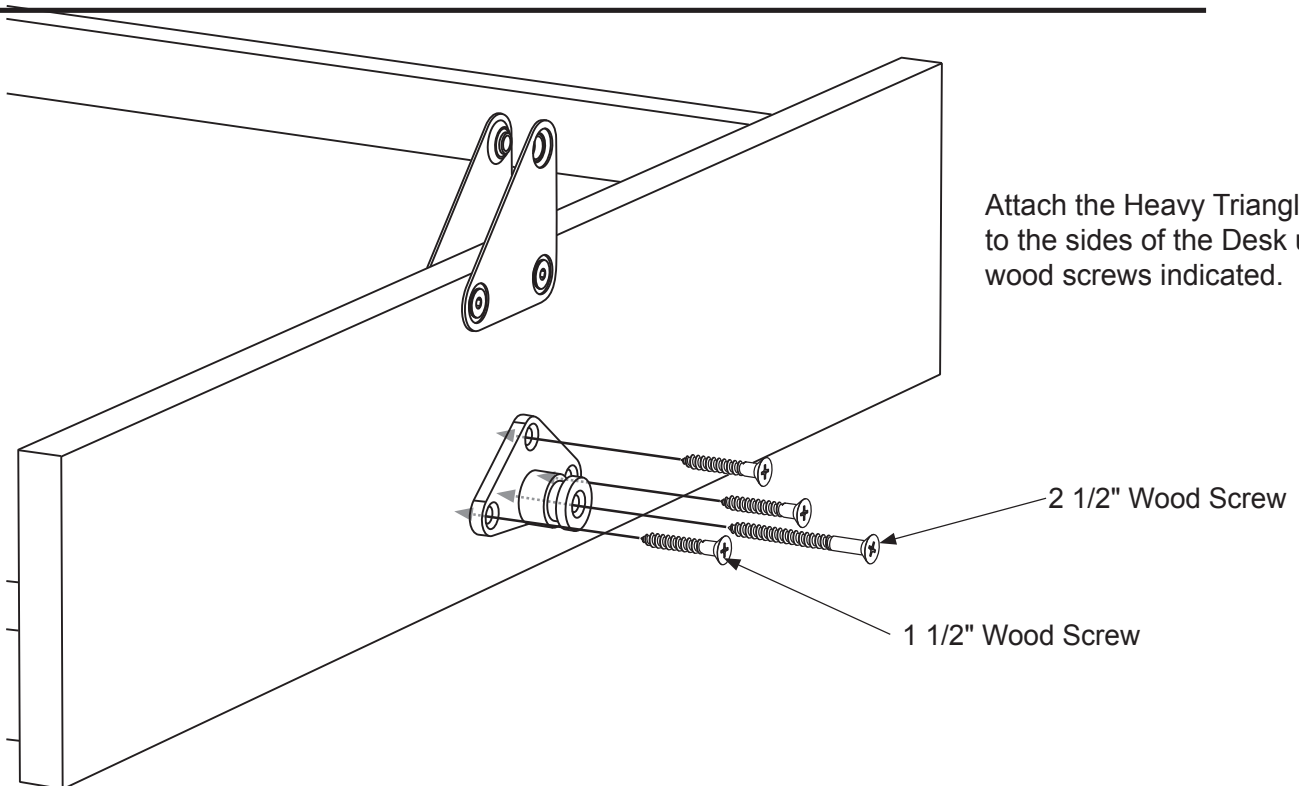

6.5mm Machine Screw (4)

Threaded Steel Barrel (2)

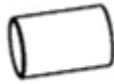

Included in Ecumenism Box

## Step 22: Bed Box Assembly

Insert a Threaded Steel Barrel into the Side Rails. Then, using the last hole in the Thin Triangle Plate, attach the Side Rails to the Desk. Once the Side Rails are attached, fully tighten all six machine screws.

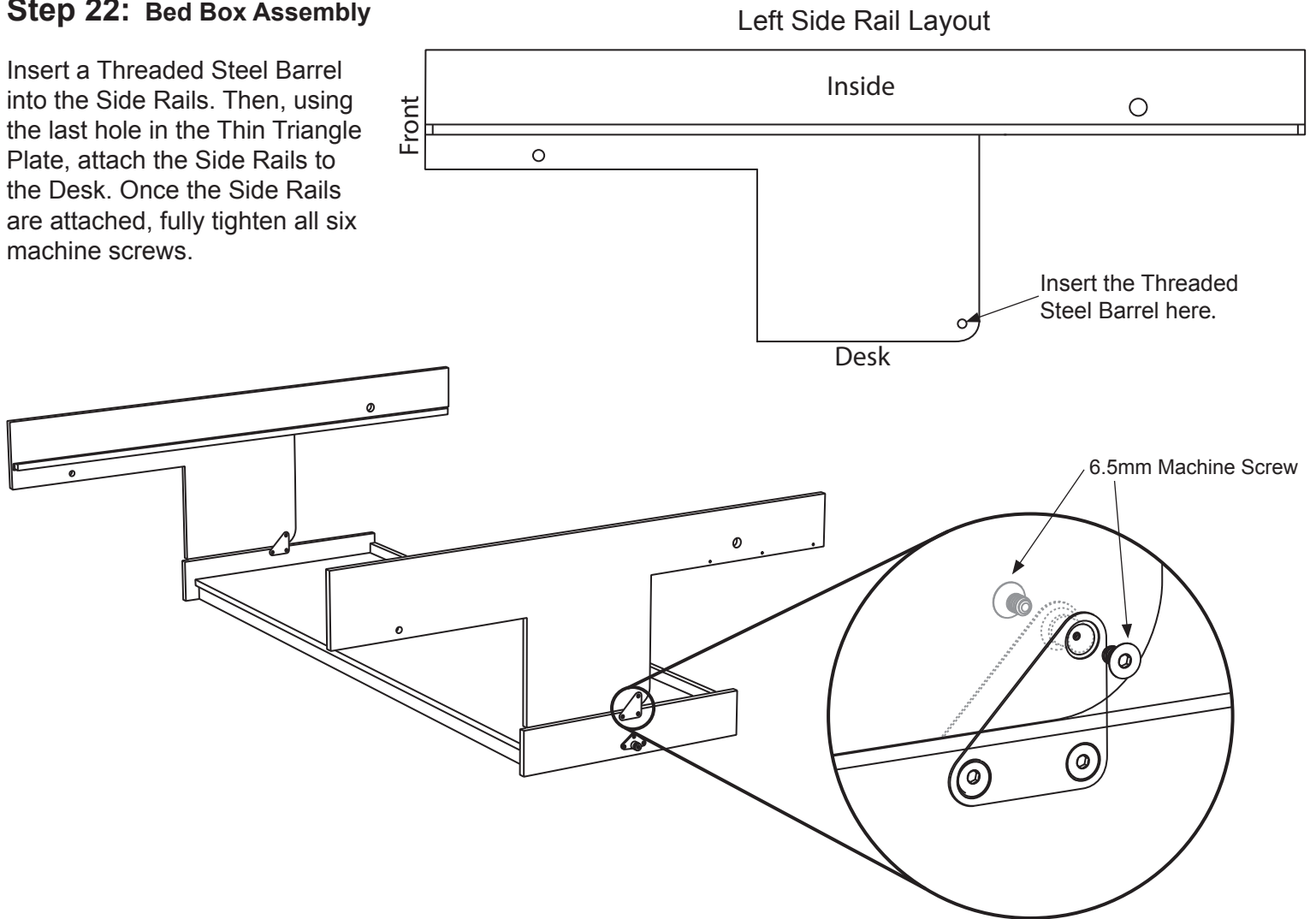

#8 x 2.5" Wood Screw  
(4)

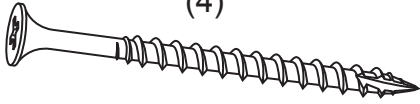

Black Decorative Washer  
(4)



---

## Step 22: Bed Box Assembly Cont.

With help, position the Top Rail in between the Side Rails. Pre drill the holes into the Front Rail using an 1/8" bit. Now use four 2.5" wood screws with decorative washers, if desired. Insert the screws from the outside of the Side Rails through the pre-drilled holes and into the Front Rail.

Helpful Hint: Use a long Pipe Clamp to hold Rail in position for accurate alignment

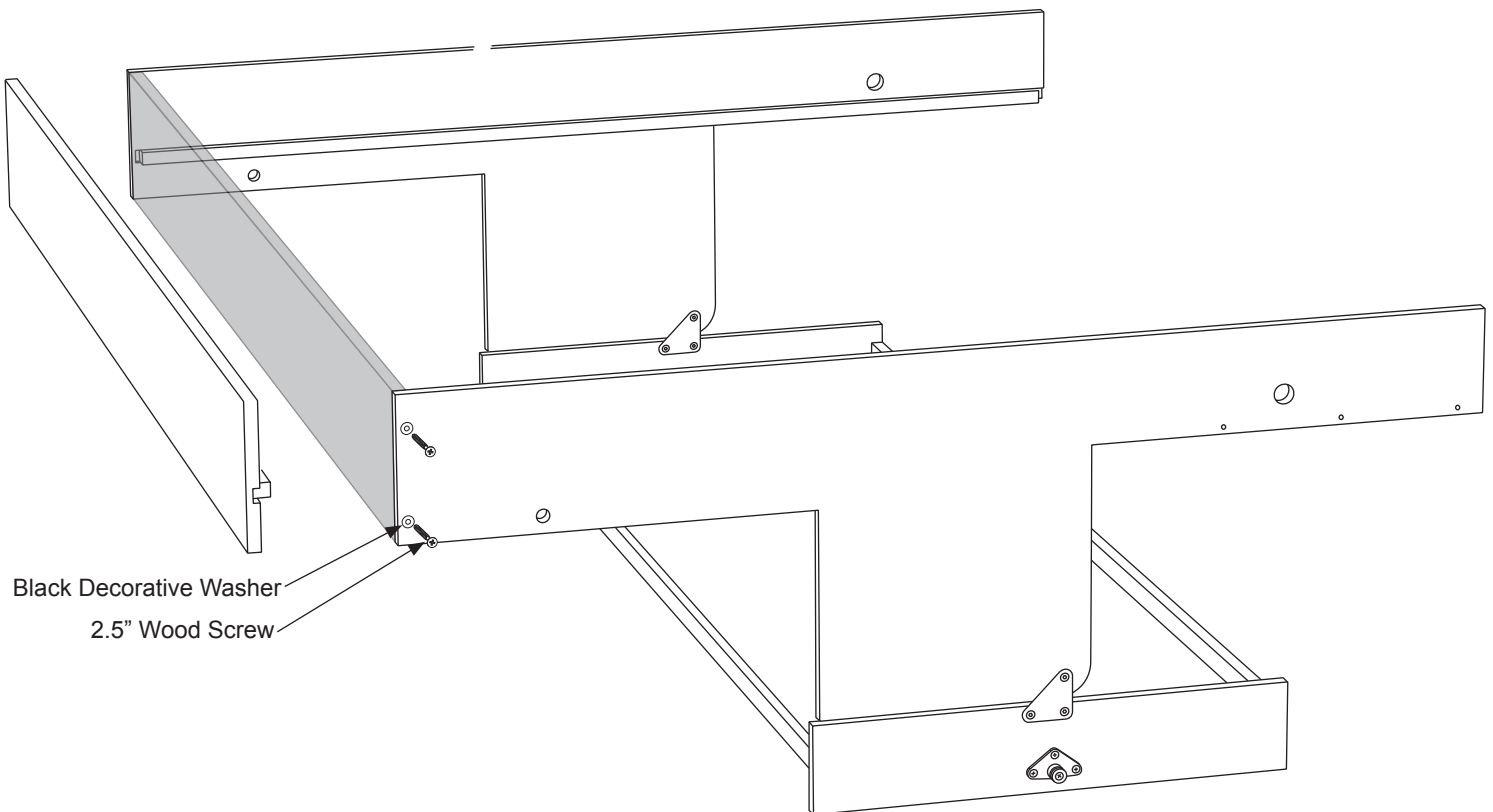

---

#8 x 2.5" Wood Screw  
(4)



Black Decorative Washer  
(4)



---

### Step 22: Bed Box Assembly Cont.

With Help, position the Back Rail between the Side Rails. Pre drill the holes into the Back Rail using an 1/8" bit. Now use four 2.5" wood screws with decorative washers, if desired. Insert the screws from the outside of the Side Rails through the pre-drilled holes and into the Back Rail.

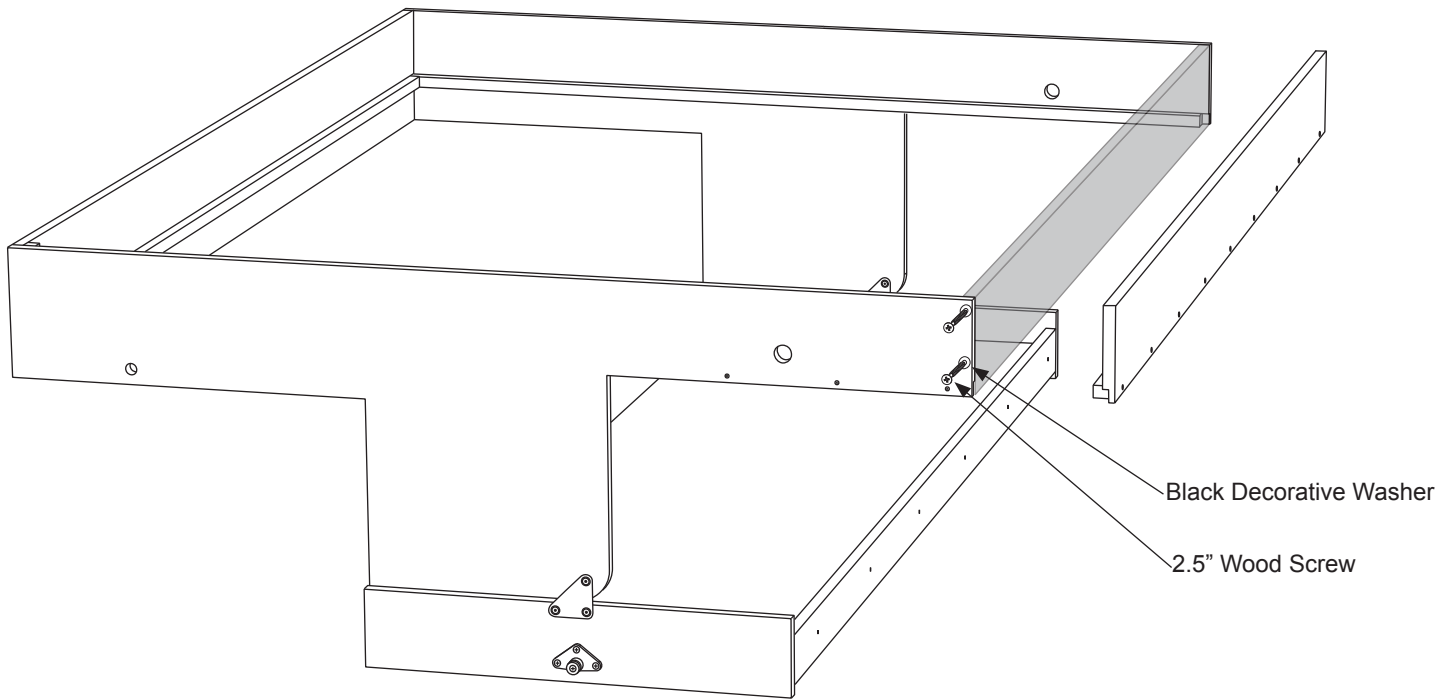

#8 x 1 1/4" Wood Screw (28)



### Step 23: Face Panel Installation

Place the Face Panels inside the rails. The face (finished or decorative side) of the Face Panels should be down. The holes around the perimeter of the Bed Face should be resting over the solid wood Rail Cleats protruding from the rails.

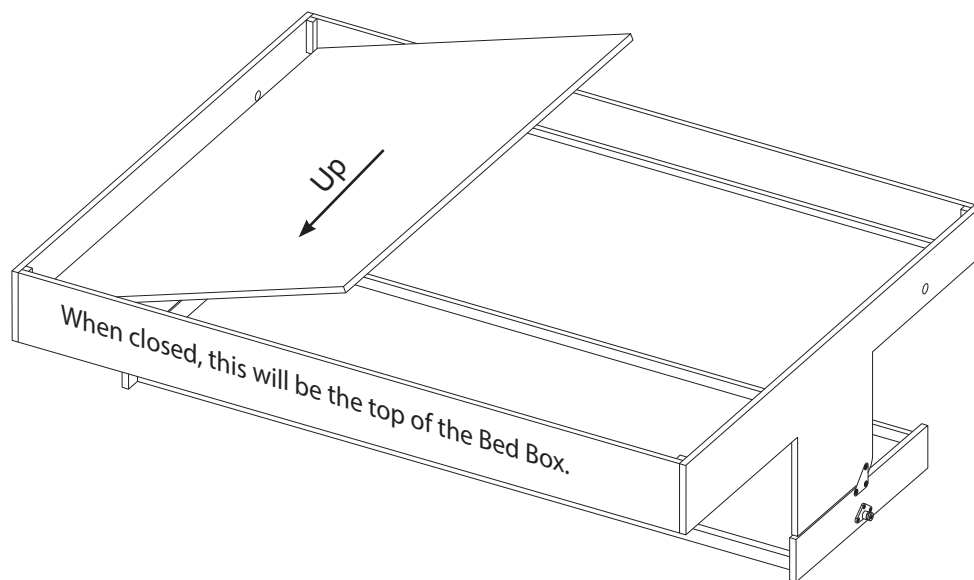

Use 28 - 1 1/4" wood screws around the perimeter, insert a screw in each hole to attach the Face Panels to the rails.

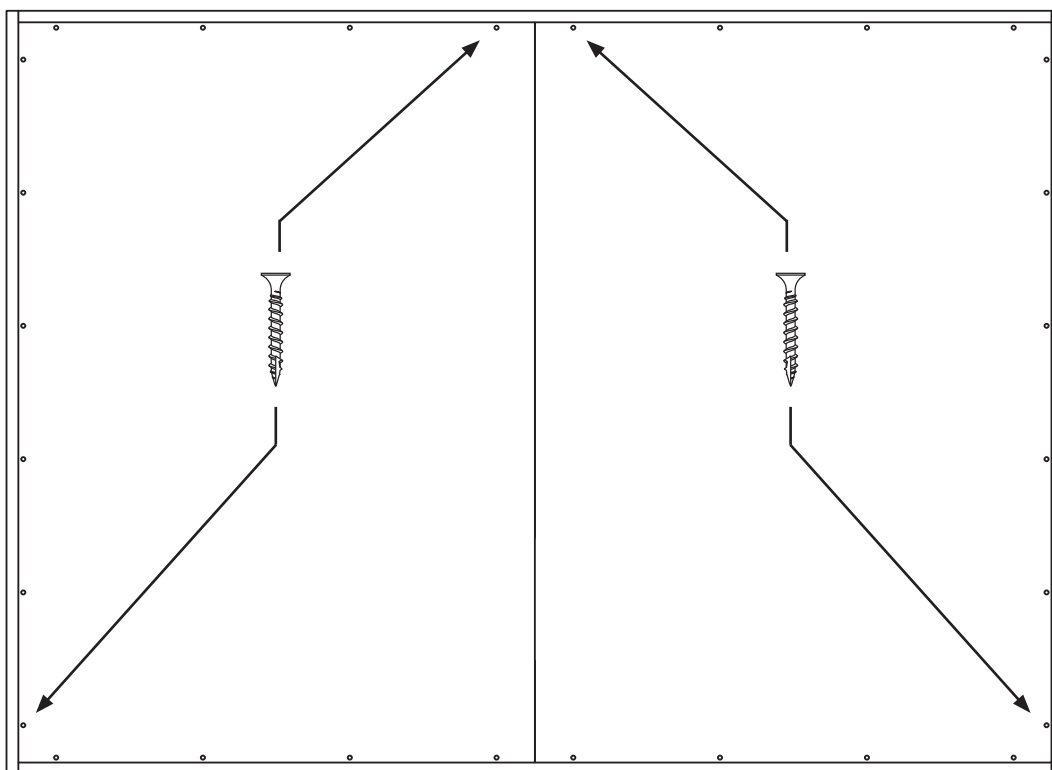

#8 x 1 1/4" Wood Screw Approx. (60)



### Step 24: Installing the Mattress Stiffener

Position the Mattress Stiffener in the Mattress Box over the seam in the Face Panels. Insure that screws will go into both halves of the Face Panel. Then use approximately 60 - 1 1/4" wood screws to

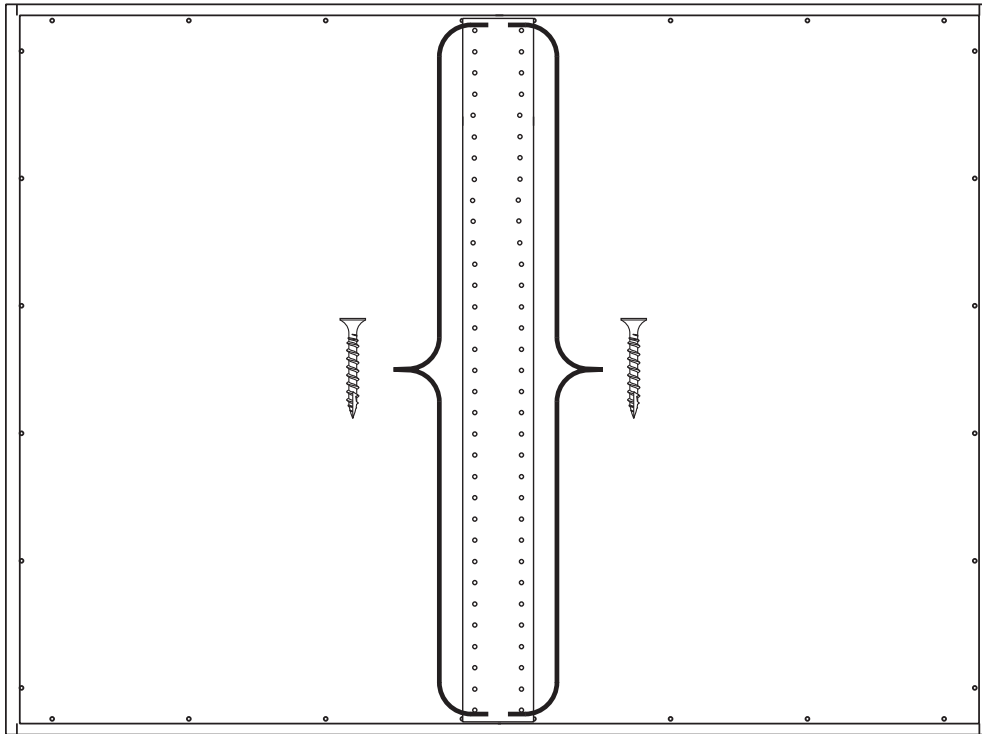

Elastic Strap Mattress Retainers

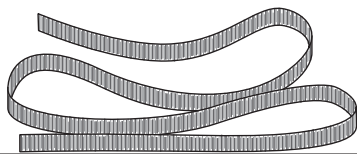

1.25" Wood Screw  
(4)



### Step 25: Elastic Strap Installation

Lay approximately 16" of Elastic Strap (sourced local) in the front corners of the bed box, at a 45° angle, as illustrated. Remove one of the screw and re insert it into the hole going through the strap to hold it in place. The Strap retains the mattress when the bed is closed.

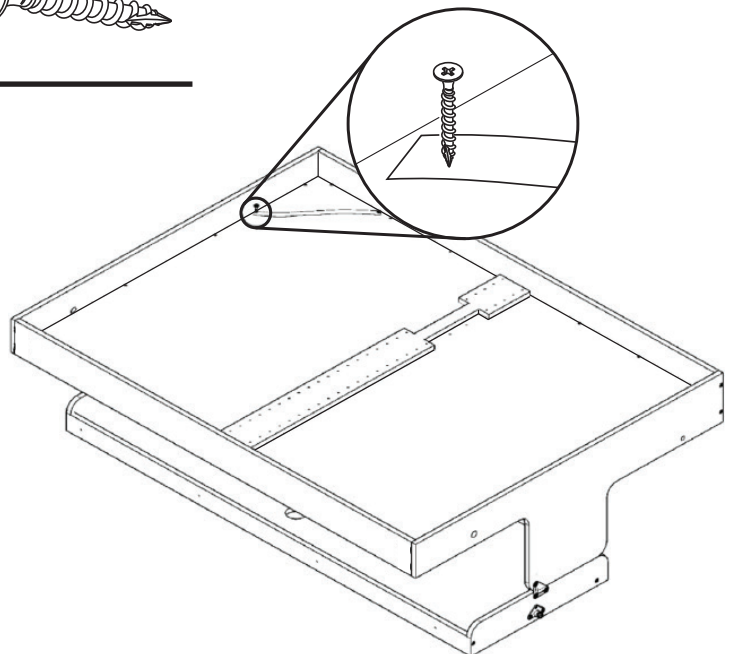

## Step 26: Positioning the Bed Box

Move the Bed Box/Desk Unit back into the Bed Cabinet Surround.

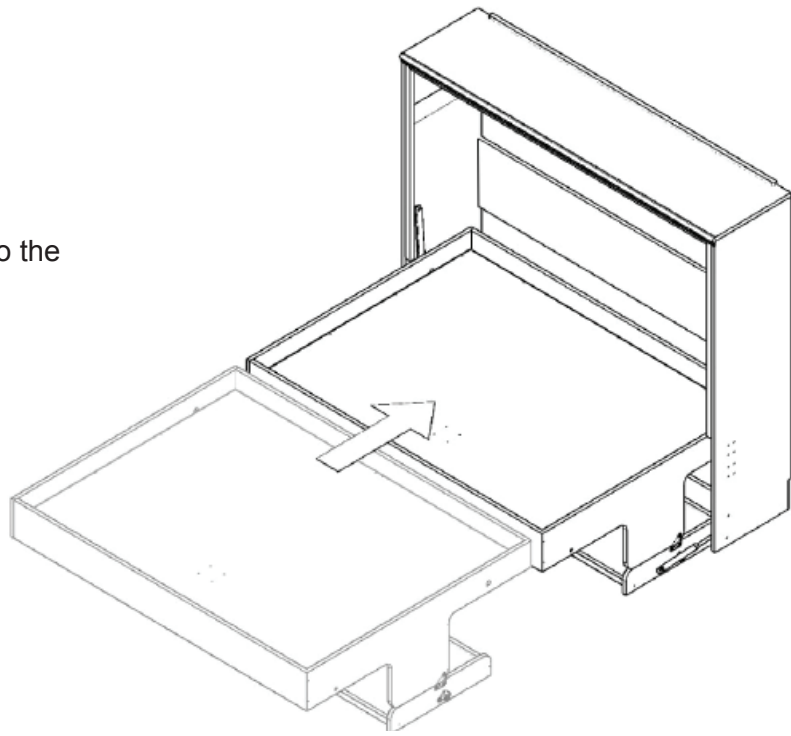

50mm Bolt (2)



Pivot Post (2)

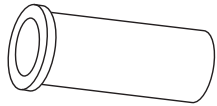

Black Flange (2)

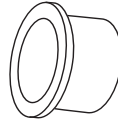

## Step 27: Pivot Hardware Installation

Line up the Pivot Hole in the Side Rail with a corresponding threaded hole in the Lifting Arm mechanism. Slide the Black Flange into the Pivot Hole. Then, insert the 50mm bolt through the Pivot Post, and thread it into the threaded hole in the Lifting Arm mechanism (**for now, just start the threads**). Repeat the process on the other side. Once the threads are started on both sides, use a 10mm Allen wrench to fully tighten the 50mm bolts.

Helpful Hint: Raise or push down ever so slightly on the outside edge of the bed box to help align the 50mm Bolt.

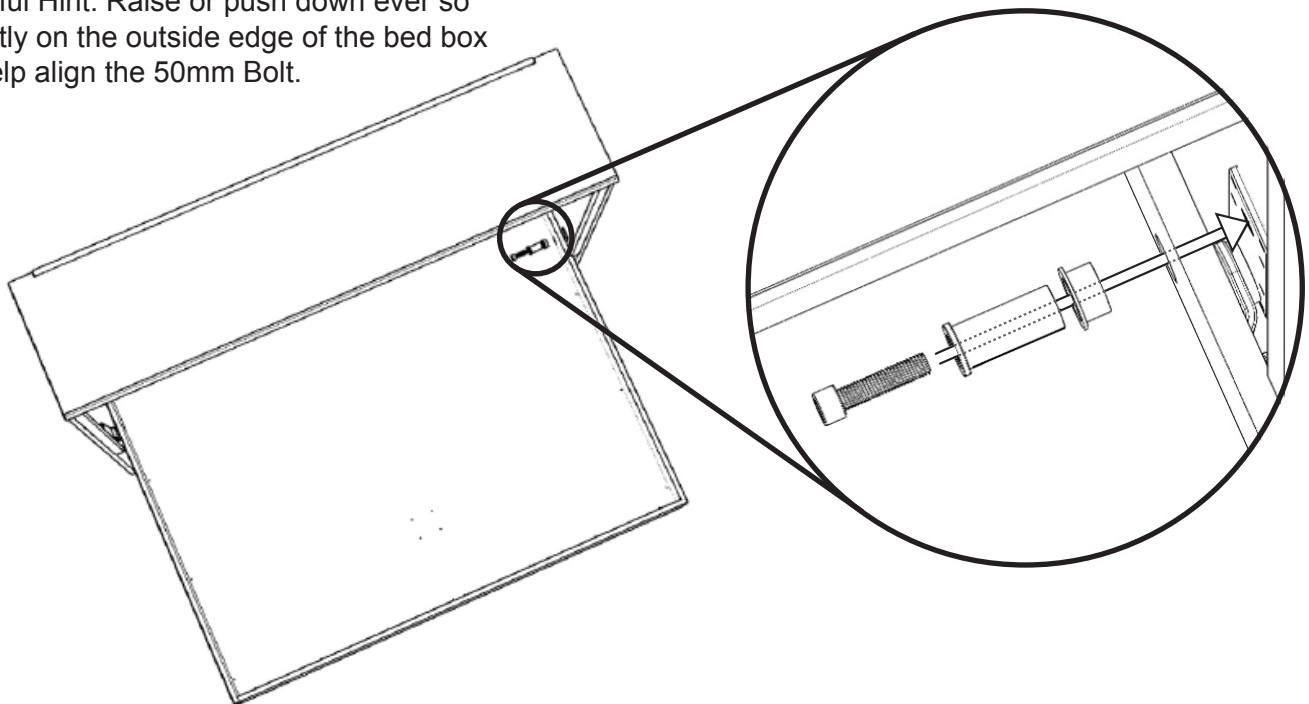

## Step 28: Connecting the Desk with the Lifting Arms

Lift the Bed Box and Desk into the closed position. **CAUTION: The Bed will fall open, if it is not held at this point. Have some one hold the Bed closed while the next step is performed.**

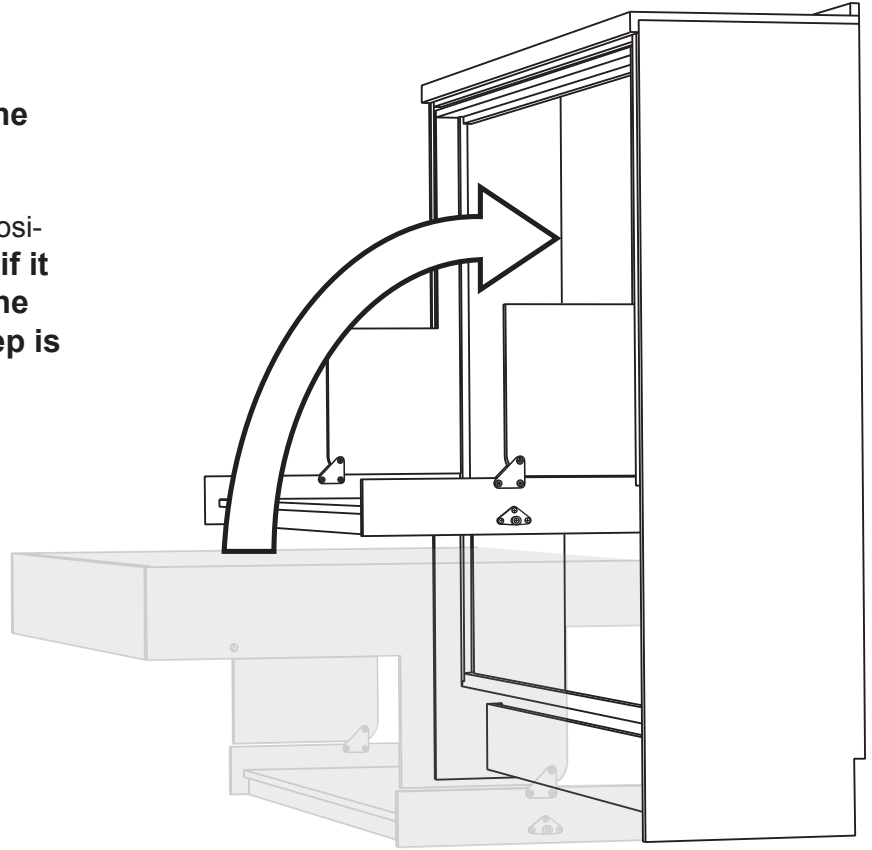

Pull the Lifting Arm down and around the Post on the end of the Desk, as illustrated. Note: you will be compressing the Piston as you pull the Arm down, and so there will be resistance so force will be required. Repeat the process on the opposite side.

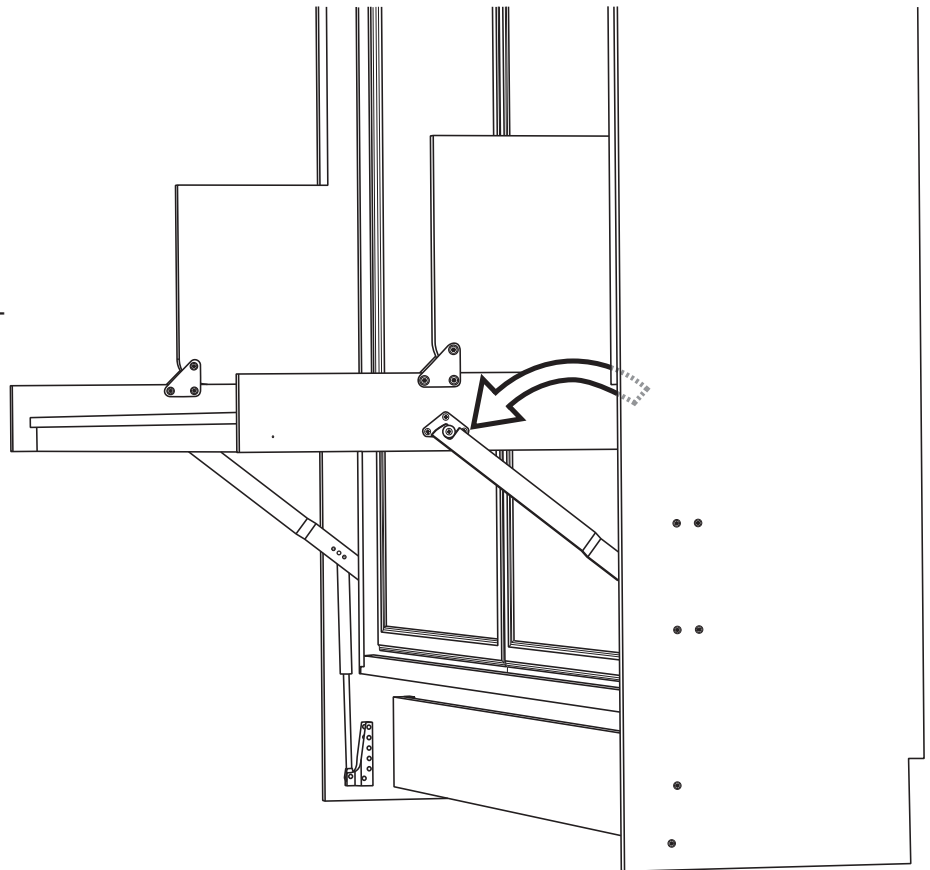



Plunge Lock (2)

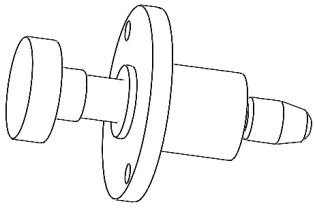

3/4" Pan-head Screw (2)

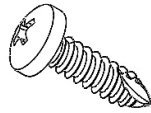

Included in Mechanism Box

Unused Plastic Barrels

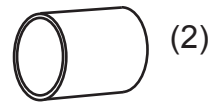

(2)

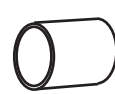

(4)

Not needed. Discard

### Step 27: Plunge Lock Installation

Attach the Plunge Locks to the Side Rails on both sides using 3/4" Pan-head wood screw (found in the mechanism box).

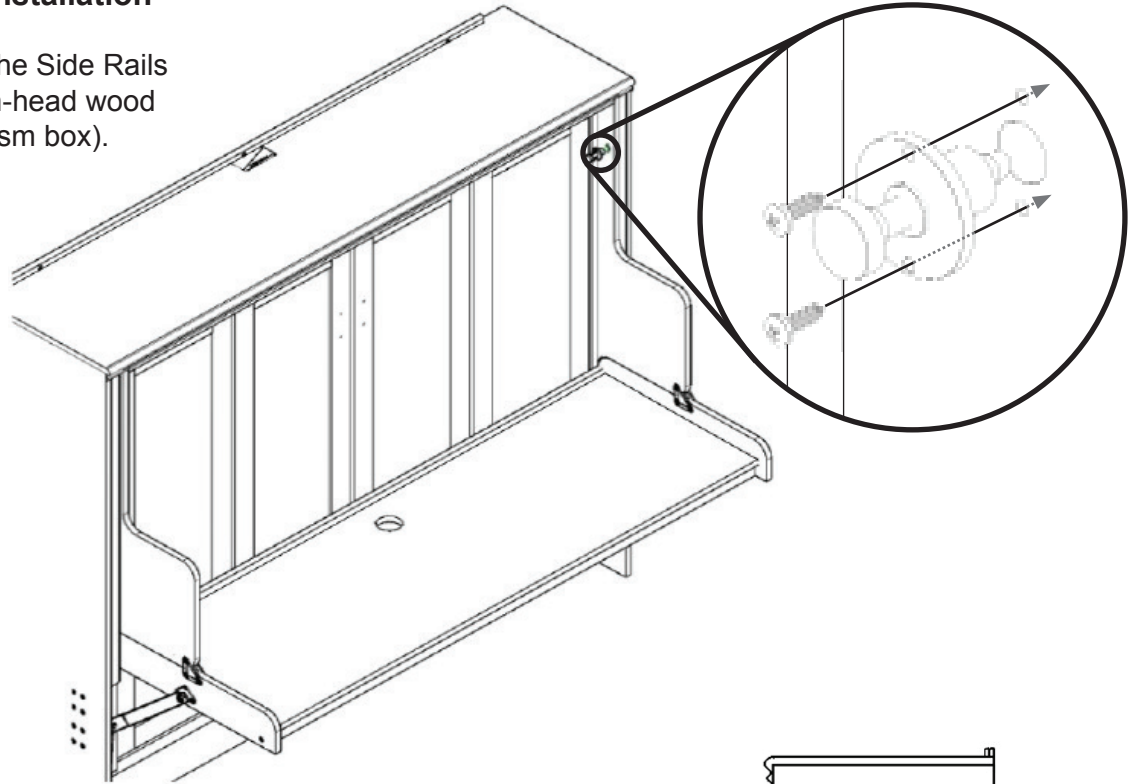

### Step 28: Bed Handle Installation

For ease in opening the bed install handles as desired.

